

# Axial piston variable pump AA4VG Series 32

## Americas

**RE-A 92003**

Edition: 06.2018

Replaces: 04.2016

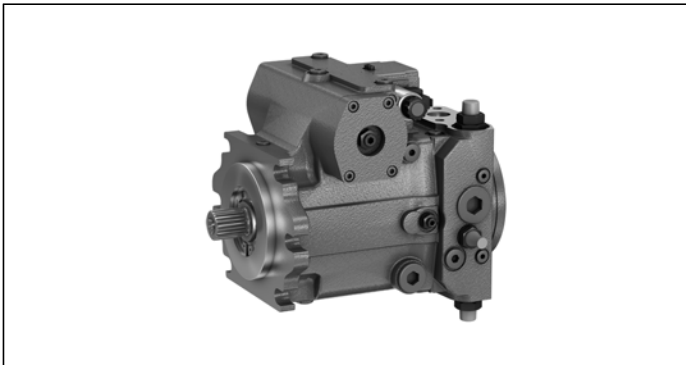

- ▶ High-pressure pump for applications in a closed circuit
- ▶ Size 28 to 125
- ▶ Nominal pressure 5800 psi (400 bar)
- ▶ Maximum pressure 6500 psi (450 bar)
- ▶ Closed circuit

### Features

- ▶ Integrated auxiliary pump for boost and pilot oil supply
- ▶ Flow direction changes smoothly when the swashplate is moved through the neutral position
- ▶ High-pressure relief valves with integrated boost function
- ▶ With adjustable pressure cut-off as standard
- ▶ Boost-pressure relief valve
- ▶ Through drive for mounting of further pumps up to same nominal size
- ▶ Large variety of controls
- ▶ Swashplate design

### Contents

Type code	2
Hydraulic fluids	5
Shaft seal	6
Working pressure range	7
Technical data	8
NV – Version without control module	11
DG – Hydraulic control, direct operated	11
HD – Proportional control, hydr., pilot-pressure related	12
HW – Proportional control, hydraulic, mechanical servo	14
EP – Proportional control, electric	16
EZ – Two-point control, electric	18
DA – Automatic control, speed related	19
ET – Electric control, direct operated	22
Dimensions, size 28 to 125	23
Dimensions, through drive	48
Overview of mounting options	51
Combination pumps AA4VG + AA4VG	52
High-pressure relief valves	53
Pressure cut-off	54
Mechanical stroke limiter	54
Stroking chamber pressure port X <sub>3</sub> and X <sub>4</sub>	55
Filtration in the boost pump suction line	56
Filtration in the boost pump pressure line	56
External boost pressure supply	59
Dimensions with filter fitted	60
Swivel angle sensor	61
Connector for solenoids	62
Rotary inch valve	63
Installation dimensions for coupling assembly	64
Installation instructions	65
Project planning notes	68
Safety instructions	68

## Type code

01	02	03	04	05	06	07	08	09	10	11	12	13	14	15	16	17	18	19	20	21	22	
AA4V	G			D					/	32		-	N									

### Axial piston unit

01	Swashplate design, variable, nominal pressure 5800 psi (400 bar), maximum pressure 6500 psi (450 bar)	AA4V
----	-------------------------------------------------------------------------------------------------------	------

### Operating mode

02	Pump, closed circuit	G
----	----------------------	---

### Size (NG)

03	Geometric displacement, see "Technical data" on page 8	in <sup>3</sup> /rev.	1.71	2.44	3.42	4.33	5.49	7.63
		cm <sup>3</sup> /rev.	28	40	56	71	90	125

### Control device

		28	40	56	71	90	125		
04	Without control module	●	●	●	●	●	●	NV	
	Proportional control, hydraulic	Pilot-pressure related $p = 87$ to 260 psi (6 to 18 bar)	○	○	●	●	●	●	HD3
		Mechanical servo	●	●	●	●	●	●	HW
	Proportional control, electric	$U = 12$ V	●	●	●	●	●	●	EP3
		$U = 24$ V	●	●	●	●	●	●	EP4
	Two-point control, electric	$U = 12$ V	●	●	●	●	●	●	EZ1
		$U = 24$ V	●	●	●	●	●	●	EZ2
	Automatic control, speed related	$U = 12$ V	●	●	●	●	●	●	DA1
		$U = 24$ V	●	●	●	●	●	●	DA2
	Hydraulic control, direct operated		○	○	●	●	●	●	DG
Electric control, direct operated, two pressure reducing valves	$U = 12$ V	●	●	●	●	-	-	ET5	
	$U = 24$ V	●	●	●	●	-	-	ET6	

### Pressure cut-off

05	Pressure cut-off (standard)	D
----	-----------------------------	---

### Neutral position switch

06	Without neutral position switch (without code)	●	
	Neutral position switch (for HW control only)	●	L

### Mechanical stroke limiter

07	Without mechanical stroke limiter (without code)	●	
	Mechanical stroke limiter, externally adjustable	●	M

### Stroking chamber pressure port

		28	40	56	71	90	125	
08	Without stroking chamber pressure port $X_3$ , $X_4$ (without code)	●	●	●	●	●	●	
	Stroking chamber pressure port $X_3$ , $X_4$	○	○	●	●	●	●	T

### DA control valve

		NV	HD	HW	DG	DA	EP	EZ		
09	Without DA control valve	●	●	●	●	-	●	●	1	
	DA control valve, fixed setting	-	●	●	●	●	●	-	2	
	DA control valve, mechanically adjustable with position lever	direction of actuation, clockwise	-	●	●	●	●	●	-	3R
		direction of actuation, counter-clockwise	-	●	●	●	●	●	-	3L
	DA control valve, fixed setting, ports for pilot control device	-	○	○	-	○	○	-	7	
	DA control valve, fixed setting and brake inch valve mounted, control with brake fluid		-	-	-	-	●	-	-	8

● = Available    ○ = On request    - = Not available     = Preferred program

01	02	03	04	05	06	07	08	09	10	11	12	13	14	15	16	17	18	19	20	21	22	
<b>AA4V</b>	<b>G</b>			<b>D</b>					/	<b>32</b>		-	<b>N</b>									

**Series**

10	Series 3, index 2	<b>32</b>
----	-------------------	-----------

**Direction of rotation**

11	Viewed on drive shaft	clockwise	<b>R</b>
		counter-clockwise	<b>L</b>

**Sealing material**

12	NBR (nitrile rubber), shaft seal in FKM (fluoroelastomer)	<b>N</b>
----	-----------------------------------------------------------	----------

**Drive shaft**

		28	40	56	71	90	125	
13	Splined shaft	for single pump		●	●	●	●	<b>S</b>
	ANSI B92.1a	for combination pump – 1st pump		- <sup>1)</sup>	- <sup>1)</sup>	●	- <sup>1)</sup>	<b>T</b>
		only for combination pump – 2nd pump		-	●	-	-	<b>U</b>

**Mounting flange**

		28	40	56	71	90	125	
14	SAE J744	2-hole		●	●	-	-	<b>C</b>
		2+4-hole		-	-	-	●	<b>F</b>

**Working port**

		28	40	56	71	90	125	
15	SAE working port <b>A</b> and <b>B</b> , top and bottom	Suction port <b>S</b> bottom		-	●	●	●	<b>52</b>
	SAE working port <b>A</b> and <b>B</b> , top and bottom	Suction port <b>S</b> top		-	○	●	-	<b>53</b>
	SAE working port <b>A</b> and <b>B</b> , same side right <sup>2)</sup>	Suction port <b>S</b> bottom		●	-	-	-	<b>60</b>
	SAE working port <b>A</b> and <b>B</b> , same side left <sup>2)</sup>	Suction port <b>S</b> bottom		-	-	-	●	<b>60</b>
	SAE working port <b>A</b> and <b>B</b> , same side right <sup>2)</sup>	Suction port <b>S</b> top		-	-	-	-	<b>63</b>

**Boost pump**

16	Without integrated boost pump	without through drive						<b>N</b>
		with through drive						<b>K</b>
	Integrated boost pump	with and without through drive						<b>F</b>

**Through drive<sup>3)</sup>**

		28	40	56	71	90	125	
17	Without through drive, versions N and F (no. 16) only	●	●	●	●	●	●	<b>00</b>
	Flange SAE J744 <sup>4)</sup>	Hub for splined shaft						
	82-2 (A)	5/8 in 9T 16/32DP <sup>5)</sup>		●	●	●	●	<b>01</b>
	101-2 (B)	7/8 in 13T 16/32DP <sup>5)</sup>		●	●	●	●	<b>02</b>
		1 in 15T 16/32DP <sup>5)</sup>		●	●	●	●	<b>04</b>
	127-2 (C) <sup>6)</sup>	1 1/4 in 14T 12/24DP <sup>5)</sup>		-	-	●	●	<b>07</b>
152-2/4 (D)	1 3/4 in 13T 8/16DP <sup>5)</sup>		-	-	-	-	<b>69</b>	

● = Available    ○ = On request    - = Not available     = Preferred program

1) Standard for combination pump – 1st pump: Shaft S  
 2) Only possible without attachment filter  
 3) Specifications for version with integrated boost pump, please contact us for version without boost pump

4) 2 = 2-hole; 4 = 4-hole  
 5) Hub for splined shaft to ANSI B92.1a  
 6) NG90 to 125 with additional 4-hole-flange (127-4)

4 **AA4VG Series 32** | Axial piston variable pump  
Type code

01	02	03	04	05	06	07	08	09	10	11	12	13	14	15	16	17	18	19	20	21	22	
AA4V	G			D				/	32		-	N										

<b>High-pressure relief valve</b>		Setting range $\Delta p$	28	40	56	71	90	125		
18	High pressure relief valve, pilot operated	1450 to 6100 psi (100 to 420 bar)	with bypass	-	-	-	●	●	●	1
	High-pressure relief valve, direct operated, fixed setting	3600 to 6100 psi (250 to 420 bar)	without bypass	●	●	●	-	-	-	3
with bypass			●	●	●	-	-	-	5	
1450 to 3600 bar (100 to 250 bar)		without bypass	●	●	●	-	-	-	4	
		with bypass	●	●	●	-	-	-	6	

<b>Filtration boost circuit/external boost pressure supply</b>		28	40	56	71	90	125	
19	Filtration in the boost pump suction line	●	●	●	●	●	●	S
	Filtration in the boost pump pressure line	●	●	●	●	●	●	D
	Ports for external boost circuit filtration ( $F_e$ and $F_a$ )	●	●	●	●	●	●	D
	Mounted cold start valve and ports for external boost circuit filtration	-	●	●	-	-	-	K
	Attachment filter with cold start valve	-	●	●	●	●	●	F
	Attachment filter with cold start valve and visual contamination indicator	-	●	●	●	●	●	P
	Attachment filter with cold start valve and electric contamination indicator	-	●	●	●	●	●	B
	External boost pressure supply (version without integrated boost pump - N00, K...)	●	●	●	●	●	●	E

<b>Swivel angle sensor</b>		28	40	56	71	90	125	
20	Without swivel angle sensor (without code)	●	●	●	●	●	●	
	Electric swivel angle sensor <sup>7)</sup>	○	○	●	○	○	○	R

<b>Connector for solenoids<sup>8)</sup></b>		28	40	56	71	90	125		
21	Without connector (without code), only for purely hydraulic control							●	
	DEUTSCH molded connector, 2-pin	without suppressor diode						●	P
		with suppressor diode (only for EZ and DA)						●	Q

<b>Standard / special version</b>			
22	Standard version	without code	
		combined with attachment part or attachment pump	-K
	Special version		-S
		combined with attachment part or attachment pump	-SK

● = Available    ○ = On request    - = Not available     = Preferred program

**Notice**

- ▶ Note the project planning notes on page 68.
- ▶ In addition to the type code, please specify the relevant technical data when placing your order.

7) Please contact us if the swivel angle sensor is used for control

8) Connectors for other electric components may deviate

## Hydraulic fluids

The AA4VG variable pump is designed for operation with HLP mineral oil according to DIN 51524.

Application instructions and requirements for hydraulic fluids should be taken from the following data sheets before the start of project planning:

- ▶ 90220: Hydraulic fluids based on mineral oils and related hydrocarbons
- ▶ 90221: Environmentally acceptable hydraulic fluids
- ▶ 90222: Fire-resistant, water-free hydraulic fluids (HFDR/HFDU)
- ▶ 90225: Axial piston units for operation with water-free and water-containing fire-resistant hydraulic fluids (HFDR, HFDU, HFAE, HFAS, HFB, HFC).

### Notes on selection of hydraulic fluid

The hydraulic fluid should be selected such that the operating viscosity in the operating temperature range is within the optimum range ( $\nu_{opt}$  see selection diagram).

### Notice

At no point of the component may the temperature be higher than 240 °F (115 °C). The temperature difference specified in the table is to be taken into account when determining the viscosity in the bearing.

Please contact us if the above conditions cannot be met due to extreme operating parameters.

### Viscosity and temperature of hydraulic fluids

	Viscosity [SUS (mm <sup>2</sup> /s)]	Temperature	Comment
Cold start	$\nu_{max} \leq 7400$ (1600)	$\theta_{St} \geq -40$ °F (-40 °C)	$t \leq 3$ min, $n \leq 1000$ rpm, without load $p \leq 725$ psi (50 bar)
	Permissible temperature difference	$\Delta T \leq 45$ °F (25 K)	between axial piston unit and hydraulic fluid in the system
Warm-up phase	$\nu = 7400$ to 1850 (1600 to 400)	$\theta = -40$ °F to -13 °F (-40 °C to -25 °C)	at $p \leq 0.7 \times p_{nom}$ , $n \leq 0.5 \times n_{nom}$ and $t \leq 15$ min
Continuous operation	$\nu = 1850$ to 60 (400 to 10)		this corresponds, for VG 46 for example, to a temperature range of +41 °F (5 °C) to +185 °F (85 °C) (see selection diagram)
		$\theta = -13$ °F to +230 °F (-25 °C to +110 °C)	measured at port <b>T</b> Observe the permissible temperature range of the shaft seal ( $\Delta T =$ approx. 9 °F (5 K) between bearing/shaft seal and port <b>T</b> )
	$\nu_{opt} = 170$ to 82 (36 to 16)		Range of optimum operating viscosity and efficiency
Short-term operation	$\nu_{min} \geq 49$ (7)		$t < 3$ min, $p < 0.3 \times p_{nom}$

### ▼ Selection diagram

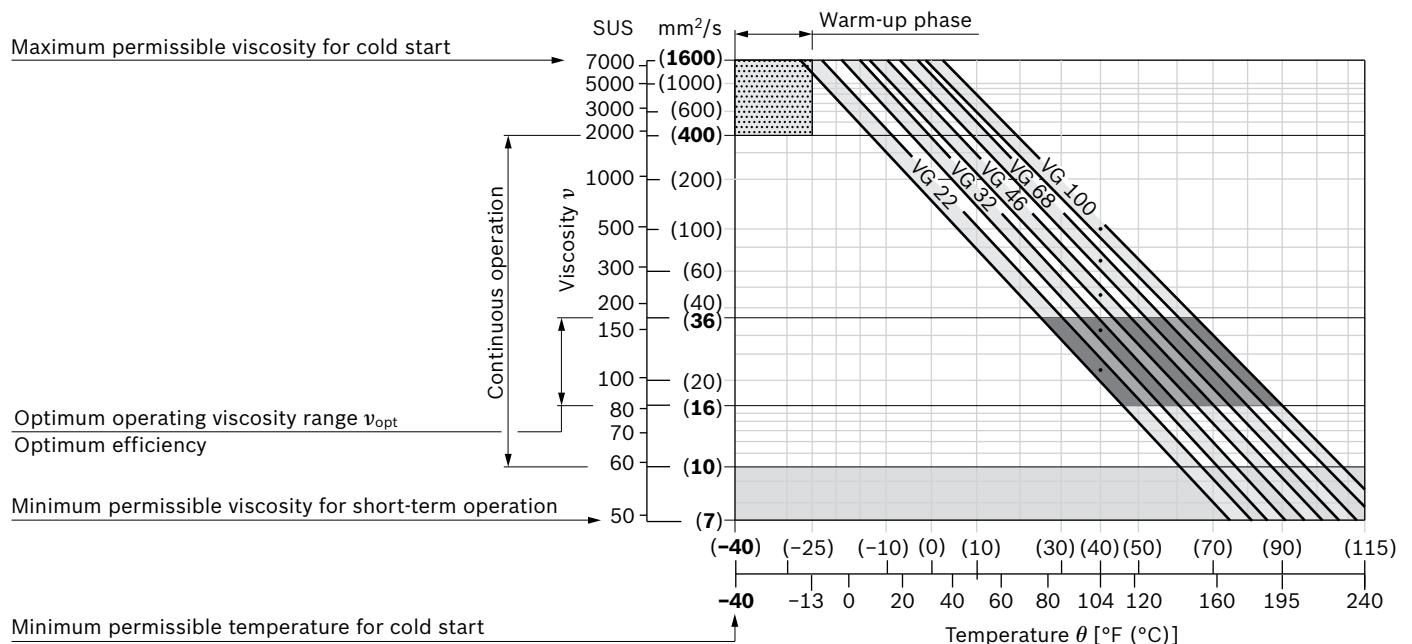

### Filtration of the hydraulic fluid

Finer filtration improves the cleanliness level of the hydraulic fluid, which increases the service life of the axial piston unit.

A cleanliness level of at least 20/18/15 is to be maintained according to ISO 4406.

Depending on the system and the application, for the AA4VG we recommend: Filter elements  $\beta_{20} \geq 100$ .

At very high hydraulic fluid temperatures (194 °F (90 °C) to maximum 230 °F (110 °C), measured at port **T**), a cleanliness level of at least 19/17/14 according to ISO 4406 is necessary.

### Shaft seal

#### Permissible pressure loading

The service life of the shaft seal is influenced by the rotational speed of the axial piston unit and the leakage pressure in the housing (case pressure). Momentary ( $t < 0.1$  s) pressure peaks of up to 145 psi (10 bar) are allowed. The service life of the shaft seal decreases with increasing frequency of pressure peaks and increasing mean differential pressure.

The case pressure must be higher than the ambient pressure.

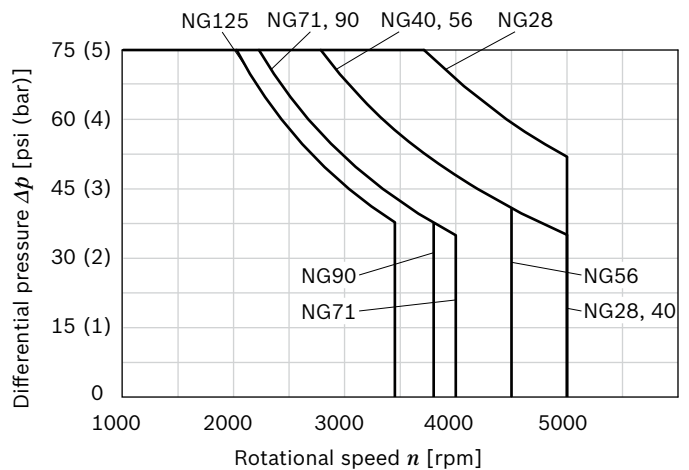

The FKM shaft seal ring may be used for leakage temperatures from -13 °F to +239 °F (-25 °C to +115 °C). For application cases below -13 °F (-25 °C), an NBR shaft seal is required (permissible temperature range: -40 °F to +194 °F (-40 °C to +90 °C)).

## Working pressure range

Pressure at working port A or B		Definition
Nominal pressure $p_{nom}$	5800 psi (400 bar)	The nominal pressure corresponds to the maximum design pressure.
Maximum pressure $p_{max}$	6500 psi (450 bar)	The maximum pressure corresponds to the maximum working pressure within the single operating period. The sum of the single operating periods must not exceed the total operating period.
Single operating period	10 s	
Total operating period	300 h	
Minimum pressure (high-pressure side)	365 psi (25 bar)	Minimum pressure at the high-pressure side (A or B) which is required to prevent damage to the axial piston unit.
Minimum pressure (low-pressure side)	145 psi (10 bar) above case pressure	Minimum pressure at the low-pressure side (A or B) which is required to prevent damage to the axial piston unit.
Rate of pressure change $R_{A max}$	130000 psi/s (9000 bar/s)	Maximum permissible rate of pressure build-up and reduction during a pressure change across the entire pressure range.
Boost pump		
Nominal pressure $p_{Sp nom}$	365 psi (25 bar)	
Maximum pressure $p_{Sp max}$	580 psi (40 bar)	
Pressure at suction port S (inlet)		
Continuous $p_{S min}$ ( $v \leq 140$ SUS) ( $v \leq 30$ mm <sup>2</sup> /s)	$\geq 12$ psi absolute ( $\geq 0.8$ bar absolute)	
Momentary, during cold start ( $t < 3$ min)	$\geq 7.5$ psi (0.5 bar) absolute	
Maximum pressure $p_{S max}$	$\leq 75$ psi (5 bar) absolute	
Control pressure		
Minimum control pressure $p_{St min}$		To ensure the function of the control, a minimum control pressure $p_{St min}$ at $n = 2000$ rpm is necessary depending on the rotational speed and working pressure
Controls EP, HD, HW	290 psi (20 bar) above case pressure	
Controls DA, DG, EZ, ET	365 psi (25 bar) above case pressure	

### ▼ Rate of pressure change $R_{A max}$

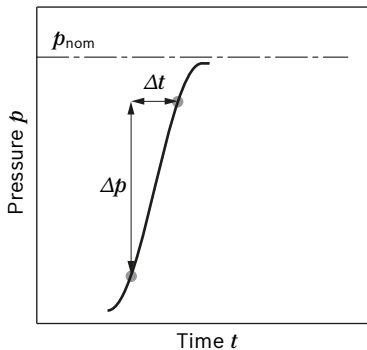

### ▼ Pressure definition

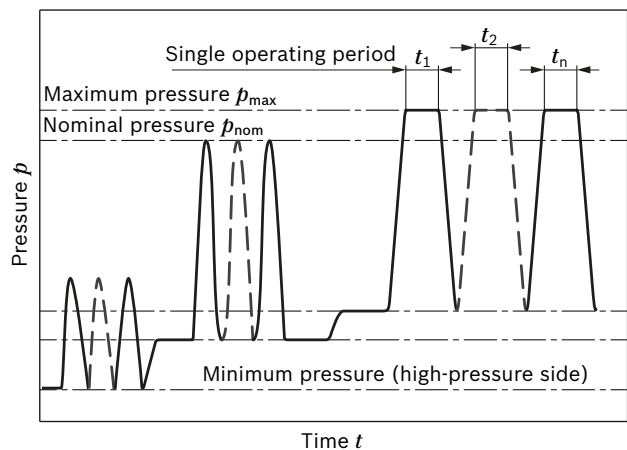

$$\text{Total operating period} = t_1 + t_2 + \dots + t_n$$

#### Notice

Working pressure range valid when using hydraulic fluids based on mineral oils. Please contact us for values for other hydraulic fluids.

## Technical data

Size			NG	28	40	56	71	90	125		
Displacement, geometric, per revolution variable pump boost pump (at $p = 290$ psi (20 bar))	$V_{g \max}$	in <sup>3</sup>	1.71	2.44	3.42	4.33	5.49	7.63			
		cm <sup>3</sup>	28	40	56	71	90	125			
	$V_{g \text{ Sp}}$	in <sup>3</sup>	0.37	0.52	0.71	1.20	1.20	1.73			
		cm <sup>3</sup>	6.1	8.6	11.6	19.6	19.6	28.3			
Rotational speed <sup>1)</sup>	maximum at $V_{g \max}$	$n_{\text{nom}}$	rpm	4250	4000	3600	3300	3050	2850		
	limited, maximum <sup>2)</sup>	$n_{\text{max1}}$	rpm	4500	4200	3900	3600	3300	3250		
	intermittent, maximum <sup>3)</sup>	$n_{\text{max2}}$	rpm	5000	5000	4500	4100	3800	3450		
	minimum	$n_{\text{min}}$	rpm	500	500	500	500	500	500		
Flow	at $n_{\text{nom}}$ and $V_{g \max}$	$q_v$	gpm	31.4	42.3	53.4	61.8	72.6	94		
			l/min	119	160	202	234	275	356		
Power <sup>4)</sup>	at $n_{\text{nom}}$ , $V_{g \max}$ and $\Delta p = 5800$ psi	$P$	hp	106	143	180	209	245	319		
			$\Delta p = 400$ bar	$P$	kW	79	107	134	156	183	238
			$\Delta p = 1450$ psi	$T$	lb-ft	131	188	263	333	423	587
Torque <sup>4)</sup>	at $V_{g \max}$ and $\Delta p = 400$ bar	$T$	Nm	178	255	357	452	573	796		
			$\Delta p = 1450$ psi	$T$	lb-ft	33	47	66	83	105	147
			$\Delta p = 100$ bar	$T$	Nm	45	64	89	113	143	199
Rotary stiffness of drive shaft	S	$c$	lb-ft/rad	23159	50892	59595	72871	116609	161010		
			kNm/rad	31.4	69	80.8	98.8	158.1	218.3		
	T	$c$	lb-ft/rad	–	–	70068	89171	–	185939		
			kNm/rad	–	–	95	120.9	–	252.1		
	U	$c$	lb-ft/rad	–	37468	–	–	79362	–		
			kNm/rad	–	50.8	–	–	107.6	–		
Moment of inertia for rotary group		$J_{\text{TW}}$	lbs-ft <sup>2</sup>	0.0522	0.0902	0.1566	0.2302	0.3536	0.5505		
			kgm <sup>2</sup>	0.0022	0.0038	0.0066	0.0097	0.0149	0.0232		
Maximum angular acceleration <sup>5)</sup>		$\alpha$	rad/s <sup>2</sup>	38000	30000	24000	21000	18000	14000		
Case volume		$V$	gal	0.24	0.29	0.40	0.34	0.40	0.55		
			l	0.9	1.1	1.5	1.3	1.5	2.1		
Weight (without through drive) approx.		$m$	lbs	64	68	84	110	132	176		
			kg	29	31	38	50	60	80		

### Notice

- ▶ Theoretical values, without efficiency and tolerances; values rounded
- ▶ Operation above the maximum values or below the minimum values may result in a loss of function, a reduced service life or in the destruction of the axial piston unit. Bosch Rexroth recommend testing the loads by means of experiment or calculation / simulation and comparison with the permissible values.

1) The values are applicable:

- for the optimum viscosity range from  $\nu_{\text{opt}} = 170$  to 82 SUS (36 to 16 mm<sup>2</sup>/s)
- for hydraulic fluid based on mineral oils (for HF hydraulic fluids, observe the technical data in 90225)

2) Valid at half corner power (e.g. at  $V_{g \max}$  and  $p_N/2$ )

3) Valid at  $\Delta p = 1000$  to 2200 psi (70 to 150 bar) or  $\Delta p < 4350$  psi (300 bar) and  $t < 0.1$  s

4) Without boost pump

### Determining the operating characteristics

$$\text{Flow } q_v = \frac{V_g \times n \times \eta_v}{231} \quad [\text{gpm}] \quad \left( \frac{V_g \times n \times \eta_v}{1000} \right) \quad [\text{l/min}]$$

$$\text{Torque } T = \frac{V_g \times \Delta p}{24 \times \pi \times \eta_{\text{mh}}} \quad [\text{lb-ft}] \quad \left( \frac{V_g \times \Delta p}{24 \times \pi \times \eta_{\text{mh}}} \right) \quad [\text{Nm}]$$

$$\text{Power } P = \frac{2 \pi \times T \times n}{33000} = \frac{q_v \times \Delta p}{1714 \times \eta_t} \quad [\text{HP}] \quad \left( \frac{2 \pi \times T \times n}{60000} = \frac{q_v \times \Delta p \times \eta_t}{600} \right) \quad [\text{kW}]$$

### Key

$V_g$  Displacement per revolution [in<sup>3</sup> (cm<sup>3</sup>)]

$\Delta p$  Differential pressure [psi (bar)]

$n$  Rotational speed [rpm]

$\eta_v$  Volumetric efficiency

$\eta_{\text{mh}}$  Hydraulic-mechanical efficiency

$\eta_t$  Total efficiency ( $\eta_t = \eta_v \times \eta_{\text{mh}}$ )

5) The data are valid for values between the minimum required and maximum permissible rotational speed.

Valid for external excitation (e.g. diesel engine 2 to 8 times rotary frequency, cardan shaft twice the rotary frequency).

The limit value is only valid for a single pump.

The load capacity of the connecting parts must be considered.

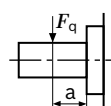
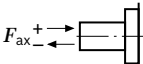

**Permissible radial and axial forces on the drive shaft**
**▼ Splined shaft ANSI B92.1a**

Size	NG	28	40	40	56	56	71		
Drive shaft		in 1	1	1 1/4	1 1/4	1 3/8	1 1/4		
Maximum radial force at distance a (from shaft collar)		$F_{q \max}$	lbf	671	958	766	1073	975	1360
			N	2983	4261	3409	4772	4338	6050
			a	in	0.75	0.75	0.94	0.94	0.94
		mm	19	19	24	24	24	24	
Maximum axial force		+ $F_{ax \max}$	lbf	350	477	477	654	654	954
			N	1557	2120	2120	2910	2910	4242
		- $F_{ax \max}$	lbf	94	198	198	355	355	620
			N	417	880	880	1490	1490	2758

Size	NG	71	90	90	125	125		
Drive shaft		in 1 3/8	1 1/4	1 3/4	1 3/4	2		
Maximum radial force at distance a (from shaft collar)		$F_{q \max}$	lbf	1236	1724	1232	1711	1497
			N	5500	7670	5478	7609	6658
			a	in	0.94	0.94	1.32	1.32
		mm	24	24	33.5	33.5	40	
Maximum axial force		+ $F_{ax \max}$	lbf	954	973	973	1361	1361
			N	4242	4330	4330	6053	6053
		- $F_{ax \max}$	lbf	620	600	600	797	797
			N	2758	2670	2670	3547	3547

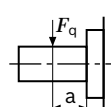
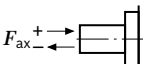
**Notice**

- ▶ The axial and radial forces generally influence the service life of the bearings.
- ▶ Special requirements apply in the case of belt drive and cardan shaft. Please contact us.

**Permissible input and through-drive torques**

Size		NG	28	40	56	71	90	125	
Torque at $V_{g \max}$ and	$\Delta p = 5800 \text{ psi}^{1)}$	T	lb-ft	131	188	263	333	423	587
	$\Delta p = 400 \text{ bar}^{1)}$	T	Nm	178	255	357	452	573	796
Maximum input torque at drive shaft <sup>2)</sup> ANSI B92.1a (SAE J744)	S	$T_{E \max}$	lb-ft	232	444	444	444	1210	1210
			Nm	314	602	602	602	1640	1640
			in	1	1 1/4	1 1/4	1 1/4	1 3/4	1 3/4
	T	$T_{E \max}$	lb-ft	-	-	715	715	-	1969
			Nm	-	-	970	970	-	2670
			in	-	-	1 3/8	1 3/8	-	2
U <sup>3)</sup>	$T_{E \max}$	lb-ft	-	232	-	-	444	-	
		Nm	-	314	-	-	602	-	
		in	-	1	-	-	1 1/4	-	
Maximum through-drive torque <sup>4)</sup>	$T_{D \max}$	lb-ft	170	232	384	487	606	819	
		Nm	231	314	521	660	822	1110	

**Distribution of torques**

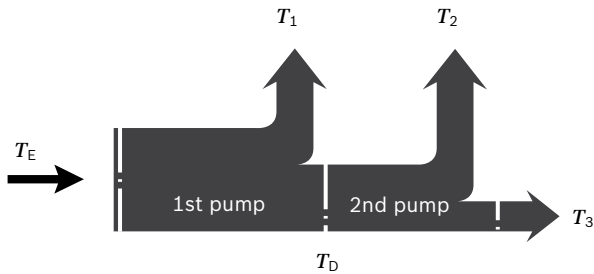

Torque at 1st pump	$T_1$
Torque at 2nd pump	$T_2$
Torque at 3rd pump	$T_3$
Input torque	$T_E = T_1 + T_2 + T_3$
	$T_E < T_{E \max}$
Through-drive torque	$T_D = T_2 + T_3$
	$T_D < T_{D \max}$

- 1) Efficiency not considered
- 2) For drive shafts free of radial force
- 3) Shaft "U" is only permitted as drive shaft on the 2nd pump on a combination pump of the same size.
- 4) Note maximum input torque for shaft S!

### NV – Version without control module

The mounting surface for the control module is machined and sealed with the standard seal for control modules and a cover plate. This version is ready for retrofitting to control modules (HD, HW, EP, EZ). When used directly for “DA” control and in combinations with “DA” control, the appropriate adjustments must be made to the spring assembly of the adjustment cylinder and control plate.

#### ▼ Standard version<sup>1)</sup>

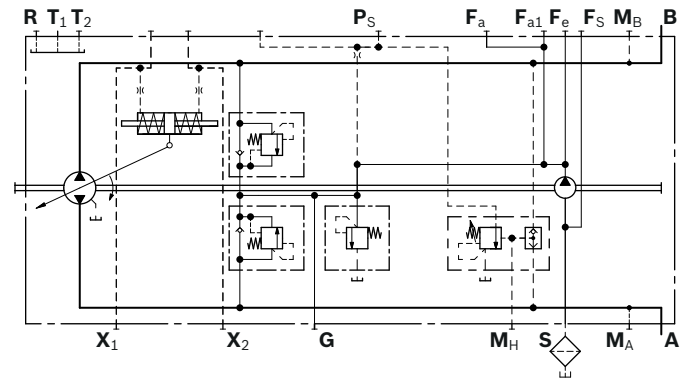

### DG – Hydraulic control, direct operated

With the direct operated hydraulic control (DG), the output flow of the pump is controlled by a hydraulic control pressure, applied directly to the stroking piston through either port **X<sub>1</sub>** or **X<sub>2</sub>**.

Flow direction is determined by which control pressure port is pressurized (refer to table below).

Pump displacement is infinitely variable and proportional to the applied control pressure, but is also influenced by system pressure and pump drive speed.

In order to use the optional built-in pressure cut-off, port **P<sub>S</sub>** must be used as the control pressure source for the selected control module.

See page 54 for a functional description of the pressure cut-off.

Maximum permissible control pressure: 580 psi (40 bar)

Use of the DG control requires a review of the engine and vehicle parameters to ensure that the pump is set up correctly. We recommend that all DG applications be reviewed by a Bosch Rexroth application engineer.

If the pump is also equipped with a DA control valve (see page 19), automotive operation is possible for travel drives.

#### ▼ Standard version<sup>1)</sup>

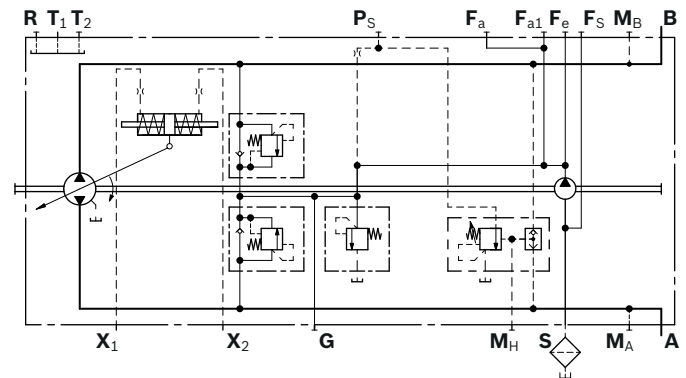

#### ▼ Version with DA control valve<sup>1)</sup>

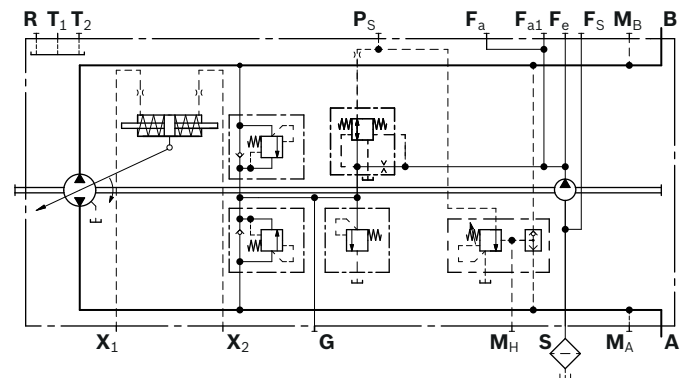

Correlation of direction of rotation, control and flow direction								
Direction of rotation	clockwise				counter-clockwise			
Size	28 to 56		71 to 125		28 to 56		71 to 125	
Control pressure	<b>X<sub>1</sub></b>	<b>X<sub>2</sub></b>	<b>X<sub>1</sub></b>	<b>X<sub>2</sub></b>	<b>X<sub>1</sub></b>	<b>X<sub>2</sub></b>	<b>X<sub>1</sub></b>	<b>X<sub>2</sub></b>
Flow direction	<b>A to B</b>	<b>B to A</b>	<b>B to A</b>	<b>A to B</b>	<b>B to A</b>	<b>A to B</b>	<b>A to B</b>	<b>B to A</b>
Working pressure	<b>M<sub>B</sub></b>	<b>M<sub>A</sub></b>	<b>M<sub>A</sub></b>	<b>M<sub>B</sub></b>	<b>M<sub>A</sub></b>	<b>M<sub>B</sub></b>	<b>M<sub>B</sub></b>	<b>M<sub>A</sub></b>

<sup>1)</sup> Size 28 without port **F<sub>a1</sub>** and **F<sub>s</sub>**

## HD – Proportional control, hydraulic, pilot-pressure related

The output flow of the pump is infinitely variable between 0 and 100%, proportional to the difference in pilot pressure applied to the two pilot pressure ports ( $Y_1$  and  $Y_2$ ).

The pilot signal, coming from an external source, is a pressure signal. Flow is negligible, as the pilot signal acts only on the control spool of the control valve.

This control spool then directs control oil into and out of the stroking cylinder to adjust pump displacement as required.

A feedback lever connected to the stroking piston maintains the pump flow for any given pilot signal within the control range.

If the pump is also equipped with a DA control valve (see page 19), automotive operation is possible for travel drives.

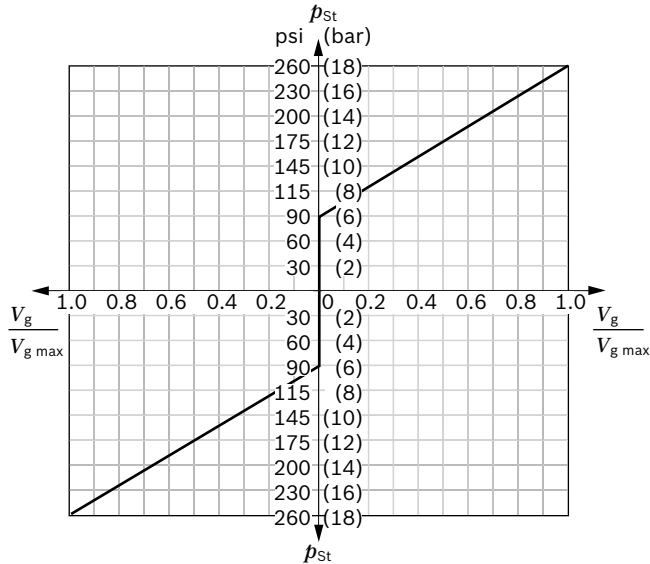

- ▶  $V_g$  = Displacement at  $p_{St}$   
 $V_{g\ max}$  = Displacement at  $p_{St} = 260$  psi (18 bar)
- ▶ Pilot signal  $p_{St} = 87$  to 260 psi (6 to 18 bar)  
 (at port  $Y_1, Y_2$ )
- ▶ Start of control at 87 psi (6 bar)
- ▶ End of control at 260 psi (18 bar)  
 (maximum displacement  $V_{g\ max}$ )

### Notice

In the neutral position, the HD control module must be vented to reservoir via the external pilot control device.

### ▼ Standard version<sup>1)</sup>

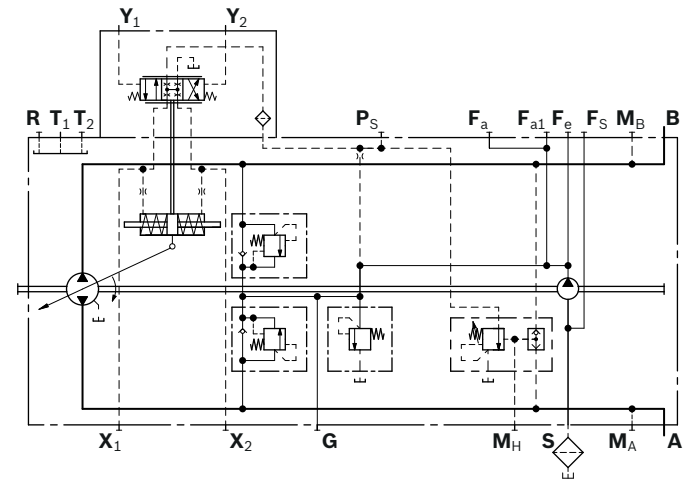

### ▼ Version with DA control valve<sup>1)</sup>

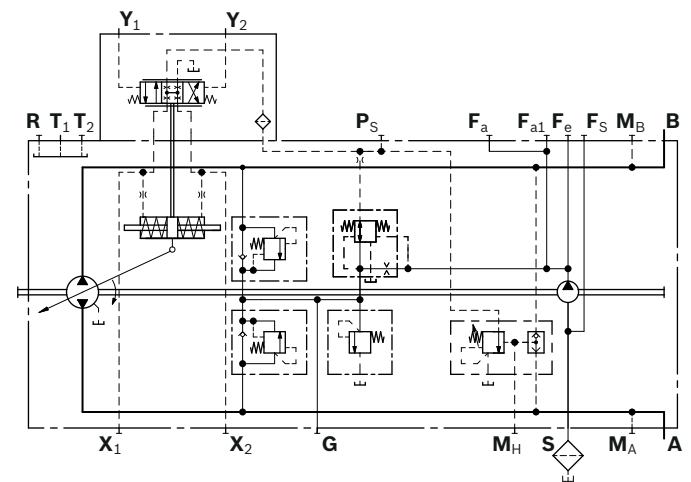

1) Size 28 without port  $F_{a1}$  and  $F_s$

<b>Correlation of direction of rotation, control and flow direction</b>								
Direction of rotation	clockwise				counter-clockwise			
Size	28 to 56		71 to 125		28 to 56		71 to 125	
Pilot signal	<b>Y<sub>1</sub></b>	<b>Y<sub>2</sub></b>	<b>Y<sub>1</sub></b>	<b>Y<sub>2</sub></b>	<b>Y<sub>1</sub></b>	<b>Y<sub>2</sub></b>	<b>Y<sub>1</sub></b>	<b>Y<sub>2</sub></b>
Control pressure	<b>X<sub>1</sub></b>	<b>X<sub>2</sub></b>	<b>X<sub>1</sub></b>	<b>X<sub>2</sub></b>	<b>X<sub>1</sub></b>	<b>X<sub>2</sub></b>	<b>X<sub>1</sub></b>	<b>X<sub>2</sub></b>
Flow direction	<b>A to B</b>	<b>B to A</b>	<b>B to A</b>	<b>A to B</b>	<b>B to A</b>	<b>A to B</b>	<b>A to B</b>	<b>B to A</b>
Working pressure	<b>M<sub>B</sub></b>	<b>M<sub>A</sub></b>	<b>M<sub>A</sub></b>	<b>M<sub>B</sub></b>	<b>M<sub>A</sub></b>	<b>M<sub>B</sub></b>	<b>M<sub>B</sub></b>	<b>M<sub>A</sub></b>

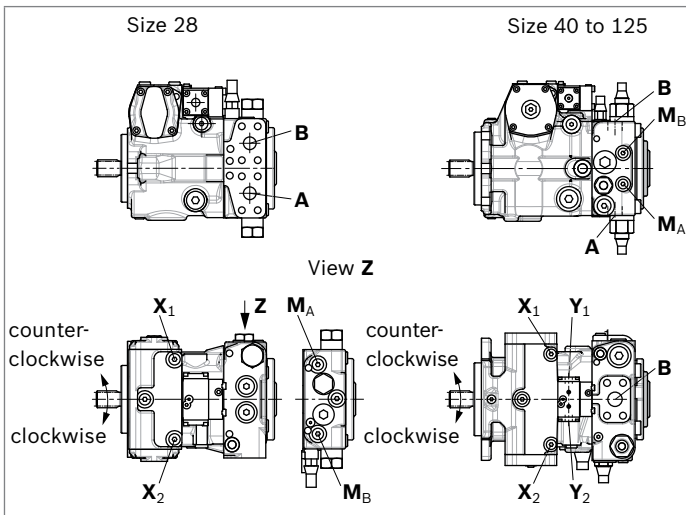

## HW – Proportional control, hydraulic, mechanical servo

The output flow of the pump is infinitely variable between 0 and 100%, proportional to the swivel angle of the control lever.

A feedback lever connected to the stroking piston maintains the pump flow for any given position of the control lever. If the pump is also equipped with a DA control valve (see page 19), automotive operation is possible for travel drives.

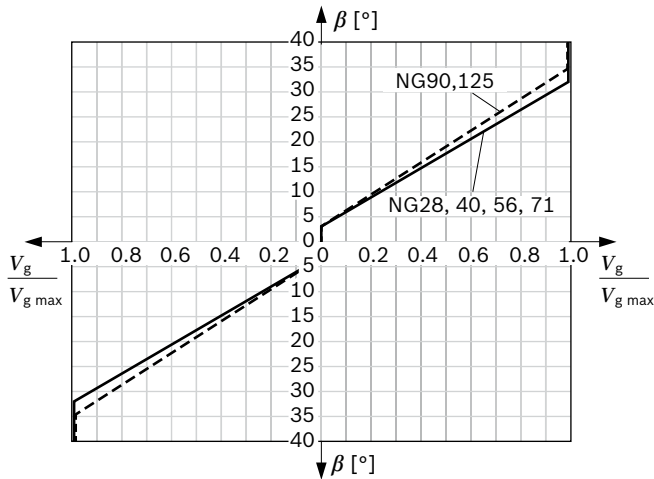

Swivel angle  $\beta$  at the control lever for pump displacement change:

- ▶ Start of control at  $\beta = \pm 3^\circ$
- ▶ End of control at  $\beta$  (max. displacement  $V_{g \max}$ )
  - Size 28 to 71 at  $\pm 32^\circ$
  - Size 90 to 125 at  $\pm 34.5^\circ$
- ▶ Rotational limit  $\beta$  of the control lever (internal)  $\pm 38^\circ$

The maximum required torque at the lever is 15 lb-in (170 Ncm). To prevent damage to the HW control module, a positive mechanical stop of  $36.5^\circ \pm 1$  must be provided for the HW control lever on the customer side.

### Notice

- ▶ Spring centering enables the pump, depending on pressure and speed, to move automatically to the neutral position ( $V_g = 0$ ) as soon as there is no longer any torque on the control lever of the HW control module.
- ▶ If necessary, the position of the lever can be changed. The procedure is defined in the instruction manual.
- ▶ On delivery, the position of the lever may differ from that shown in the drawing.

### Option: Neutral position switch

The switch contact in the neutral position switch is closed when the control lever on the HW control module is in its neutral position. The switch opens when the control lever is moved out of the central position in either direction. Thus, the neutral position switch provides a monitoring function for drive units that require the pump to be in the neutral position during certain operating conditions (e.g. starting diesel engines).

### Technical Data

Load capacity	20 A (continuous), without switching operations
Switching capacity	15 A / 32 V (resistive load) 4 A / 32 V (inductive load)
Connector version	DEUTSCH DT04-2P-EP04 (mating connector, see page 62)

### ▼ Standard version<sup>1)</sup>

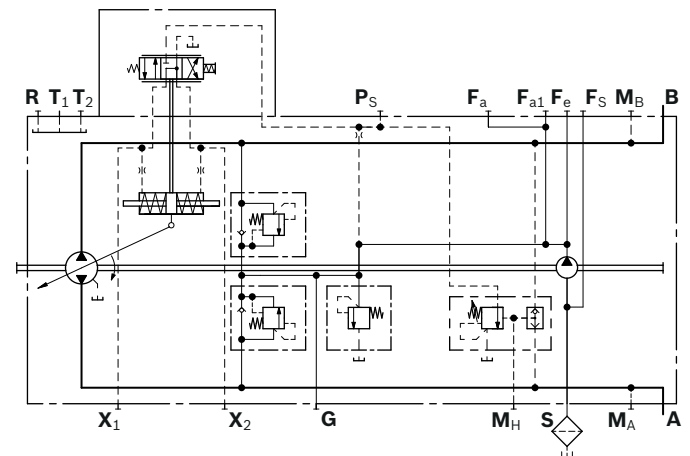

### ▼ Version with DA control valve and neutral position switch<sup>1)</sup>

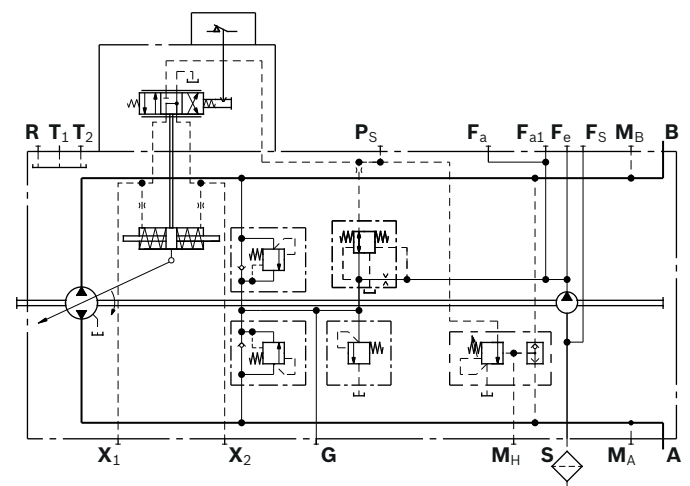

1) Size 28 without port  $F_{a1}$  and  $F_s$

Correlation of direction of rotation, control and flow direction								
Direction of rotation	clockwise				counter-clockwise			
Size	28 to 56		71 to 125		28 to 56		71 to 125	
Lever direction	a	b	a	b	a	b	a	b
Control pressure	X <sub>2</sub>	X <sub>1</sub>	X <sub>2</sub>	X <sub>1</sub>	X <sub>2</sub>	X <sub>1</sub>	X <sub>2</sub>	X <sub>1</sub>
Flow direction	B to A	A to B	A to B	B to A	A to B	B to A	B to A	A to B
Working pressure	M <sub>A</sub>	M <sub>B</sub>	M <sub>B</sub>	M <sub>A</sub>	M <sub>B</sub>	M <sub>A</sub>	M <sub>A</sub>	M <sub>B</sub>

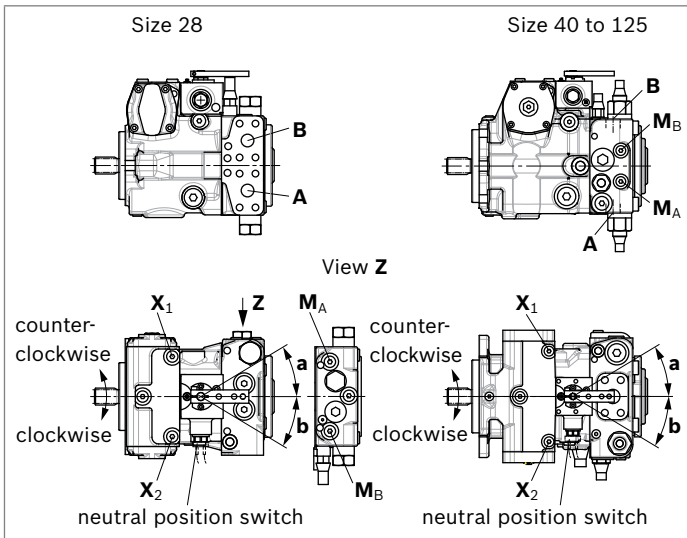

## EP – Proportional control, electric

The output flow of the pump is infinitely variable between 0 and 100%, proportional to the electrical current supplied to solenoid **a** or **b**.

The electrical energy is converted into a force acting on the control spool.

This control spool then directs control oil into and out of the stroking cylinder to adjust pump displacement as required.

A feedback lever connected to the stroking piston maintains the pump flow for any given current within the control range.

If the pump is also equipped with a DA control valve (see page 19), automotive operation is possible for travel drives.

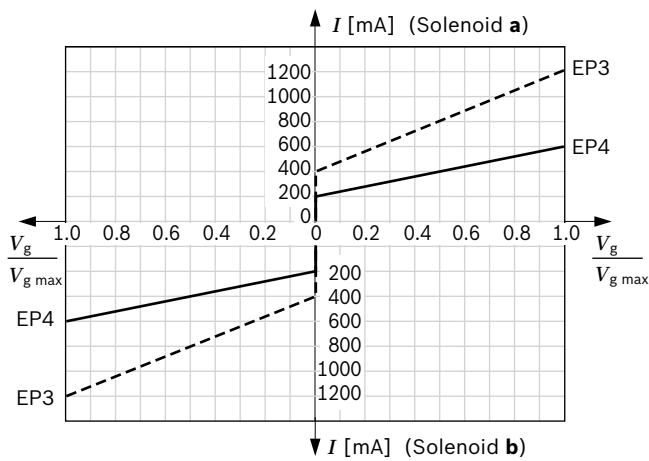

### Notice

The proportional solenoids do not have manual override. Proportional solenoids with manual override and spring return are available on request.

Technical data, solenoid	EP3	EP4
Voltage	12 V ( $\pm 20\%$ )	24 V ( $\pm 20\%$ )
Control current		
Start of control at $V_g = 0$	400 mA	200 mA
End of control at $V_g \max$	1200 mA	600 mA
Current limit	1.54 A	0.77 A
Nominal resistance (at 68 °F (20 °C))	5.5 $\Omega$	22.7 $\Omega$
Dither		
Frequency	100 Hz	100 Hz
Minimum oscillation range <sup>1)</sup>	240 mA	120 mA
Duty cycle	100%	100%
Type of protection: see connector version page 62		

Various BODAS controllers with application software and amplifiers are available for controlling the proportional solenoids.

Further information can also be found on the Internet at [www.boschrexroth.com/mobile-electronics](http://www.boschrexroth.com/mobile-electronics)

### ▼ Standard version<sup>2)</sup>

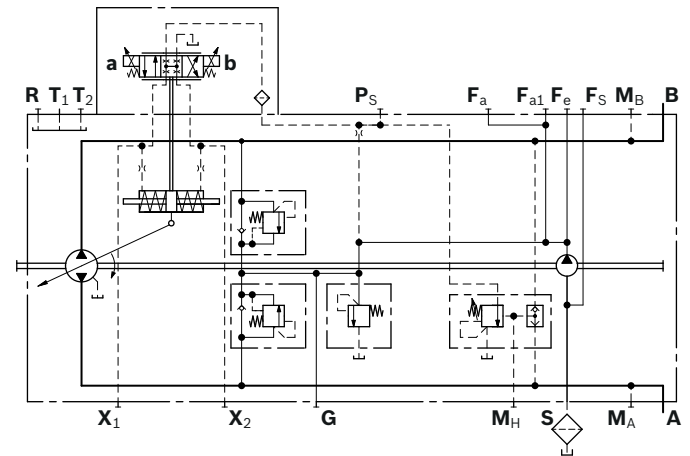

### ▼ Version with DA control valve<sup>2)</sup>

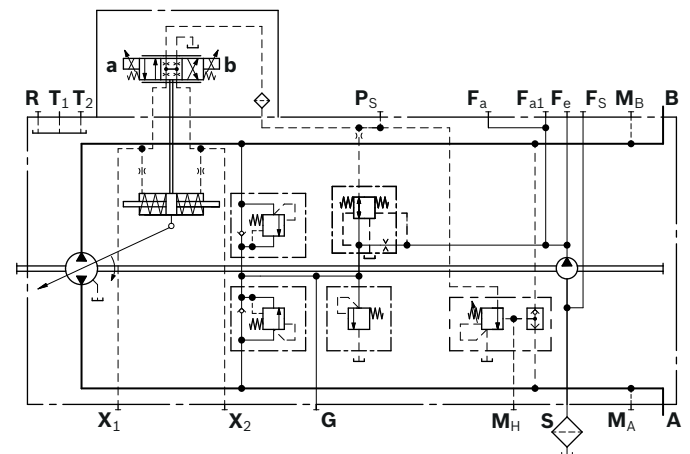

1) Minimum required oscillation range of the control current  $\Delta I_{p-p}$  (peak to peak) within the respective control range (start of control to end of control)

2) Size 28 without port **F<sub>a1</sub>** and **F<sub>s</sub>**



<b>Correlation of direction of rotation, control and flow direction</b>								
Direction of rotation	clockwise				counter-clockwise			
Size	28 to 56		71 to 125		28 to 56		71 to 125	
Actuation of solenoid	<b>a</b>	<b>b</b>	<b>a</b>	<b>b</b>	<b>a</b>	<b>b</b>	<b>a</b>	<b>b</b>
Control pressure	<b>X<sub>1</sub></b>	<b>X<sub>2</sub></b>	<b>X<sub>1</sub></b>	<b>X<sub>2</sub></b>	<b>X<sub>1</sub></b>	<b>X<sub>2</sub></b>	<b>X<sub>1</sub></b>	<b>X<sub>2</sub></b>
Flow direction	<b>A to B</b>	<b>B to A</b>	<b>B to A</b>	<b>A to B</b>	<b>B to A</b>	<b>A to B</b>	<b>A to B</b>	<b>B to A</b>
Working pressure	<b>M<sub>B</sub></b>	<b>M<sub>A</sub></b>	<b>M<sub>A</sub></b>	<b>M<sub>B</sub></b>	<b>M<sub>A</sub></b>	<b>M<sub>B</sub></b>	<b>M<sub>B</sub></b>	<b>M<sub>A</sub></b>

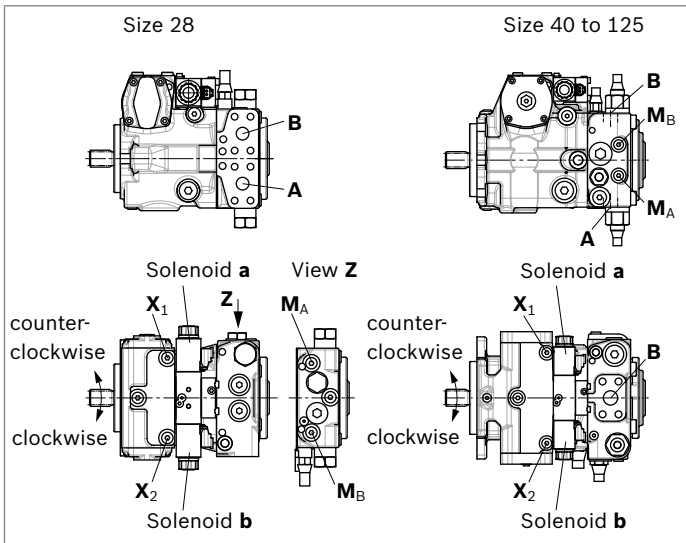

## EZ – Two-point control, electric

By actuating either switching solenoid **a** or **b**, internal control pressure is applied directly to the stroking piston and the pump swivels to maximum displacement. The EZ control enables pump flow to be switched between  $V_g = 0$  and  $V_{g \max}$ .

Flow direction is determined by which solenoid is energized.

Technical data, solenoid	EZ1	EZ2
Voltage	12 V ( $\pm 20\%$ )	24 V ( $\pm 20\%$ )
Neutral position $V_g = 0$	de-energized	de-energized
Position $V_g \max$	energized	energized
Nominal resistance (at 68 °F (20 °C))	5.5 $\Omega$	21.7 $\Omega$
Nominal power	26.2 W	26.5 W
Minimum active current required	1.32 A	0.67 A
Duty cycle	100%	100%
Type of protection: see connector version page 62		

### ▼ Standard version<sup>1)</sup>

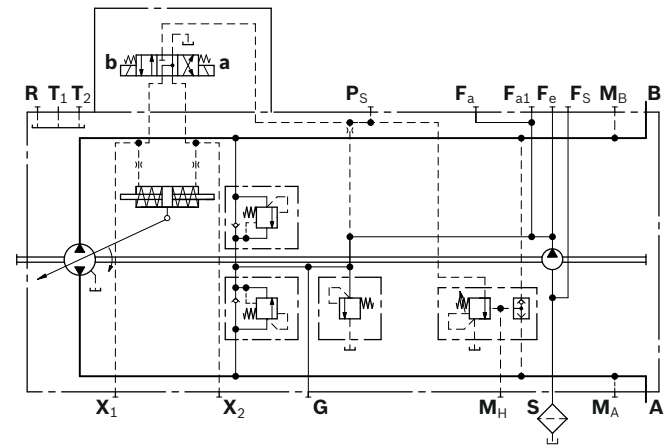

Correlation of direction of rotation, control and flow direction								
Direction of rotation	clockwise				counter-clockwise			
	Size 28 to 56		Size 71 to 125		Size 28 to 56		Size 71 to 125	
Actuation of solenoid	<b>a</b>	<b>b</b>	<b>a</b>	<b>b</b>	<b>a</b>	<b>b</b>	<b>a</b>	<b>b</b>
Control pressure	<b>X<sub>2</sub></b>	<b>X<sub>1</sub></b>	<b>X<sub>2</sub></b>	<b>X<sub>1</sub></b>	<b>X<sub>2</sub></b>	<b>X<sub>1</sub></b>	<b>X<sub>2</sub></b>	<b>X<sub>1</sub></b>
Flow direction	<b>B to A</b>	<b>A to B</b>	<b>A to B</b>	<b>B to A</b>	<b>A to B</b>	<b>B to A</b>	<b>B to A</b>	<b>A to B</b>
Working pressure	<b>M<sub>A</sub></b>	<b>M<sub>B</sub></b>	<b>M<sub>B</sub></b>	<b>M<sub>A</sub></b>	<b>M<sub>B</sub></b>	<b>M<sub>A</sub></b>	<b>M<sub>A</sub></b>	<b>M<sub>B</sub></b>

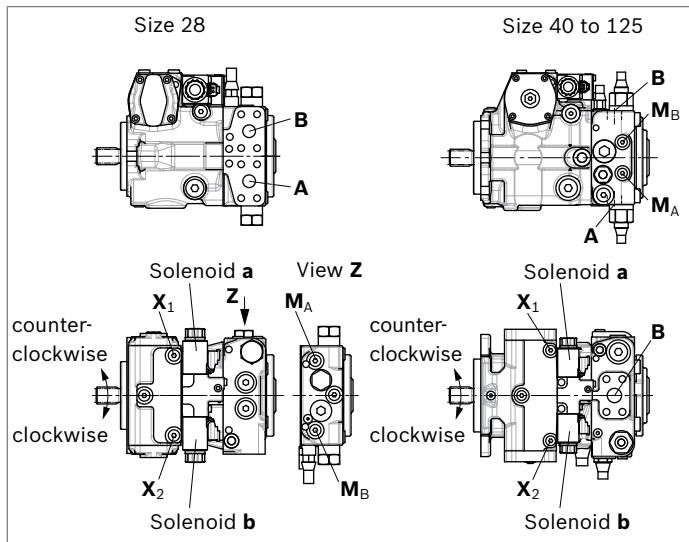

1) Size 28 without port **F<sub>a1</sub>** and **F<sub>s</sub>**

## DA – Automatic control, speed related

The DA closed loop control is an engine speed-dependent system for travel drives. The built-in DA control valve generates a pilot pressure that is proportional to pump (engine) drive speed. This pilot pressure is directed to the stroking cylinder of the pump by an electromagnetically actuated 4/3-way directional valve. The pump displacement is infinitely variable in each flow direction and is influenced by both pump drive speed and system pressure. The flow direction (e.g. machine moving forward or backward) is determined by either solenoid **a** or **b** being activated. Increasing the pump drive speed generates a higher pilot pressure from the DA control valve, with a subsequent increase in pump flow.

Depending on the selected pump operating characteristics, increasing system pressure (e.g. machine load) causes the pump to swivel back towards a smaller displacement. An overload protection for the engine (against stalling) is achieved by combining this pressure-dependent reduction in pump stroke with a reduction in pilot pressure as the engine speed drops.

Any additional power requirement, e.g. for hydraulic functions from attachments, could cause the engine speed to drop further. This will cause a further reduction in pilot pressure and thus of the pump displacement. Automatic power distribution and full exploitation of the available power are achieved in this way, both for the travel drive and for the implement hydraulics, with priority given to the implement hydraulics.

Various override options are available for DA control function to allow controlled operation of the implement hydraulics with high rpm at reduced vehicle speed.

The DA control valve can also be used in pumps with EP, DG, HW and HD control modules to protect the combustion engine against overload.

### Notice

DA closed loop control is only suitable for certain types of travel drive systems and requires review of the engine and vehicle parameters to ensure that the pump is used correctly and that machine operation is safe and efficient. We recommend that all DA applications be reviewed by a Bosch Rexroth application engineer.

Technical data, solenoid	DA1	DA2
Voltage	12 V (±20%)	24 V (±20%)
Neutral position $V_g = 0$	de-energized	de-energized
Position $V_g \text{ max}$	energized	energized
Nominal resistance (at 68 °F (20° C))	5.5 Ω	21.7 Ω
Nominal power	26.2 W	26.5 W
Minimum required active current	1.32 A	0.67 A
Duty cycle	100%	100%
Type of protection: see connector version page 62		

### DA..2 – DA control valve, fixed setting

Pilot pressure is generated in relation to drive speed.

#### ▼ DA control valve, fixed setting, DA1D2/DA2D2<sup>1)</sup>

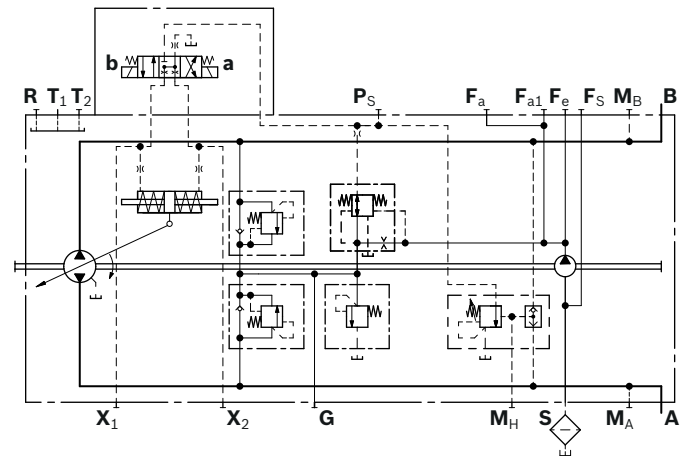

1) Size 28 without port  $F_{a1}$  and  $F_s$

**DA..3 – DA control valve, mechanically adjustable with position lever**

Pilot pressure is generated in relation to drive speed.

Any reduction of pilot pressure possible, independently of drive speed, through mechanical actuation of the position lever (inch function).

The maximum permissible actuation torque at the position lever is  $T_{max} = 3 \text{ lb-ft}$  (4 Nm).

Maximum angle of rotation  $70^\circ$ , lever position: any.

**DA..3R**

Direction of actuation of the position lever: clockwise

**DA..3L**

Direction of actuation of the position lever: counter-clockwise

▼ **Circuit diagram DA1D3/DA2D3<sup>1)</sup>**

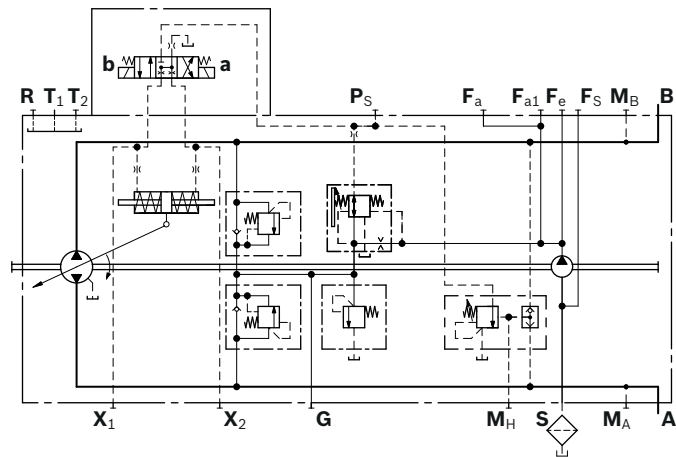

**DA..7 – DA control valve, fixed setting, ports for pilot control device as inch valve**

Any reduction of the pilot pressure possible, independent of the drive speed is achieved by the mechanical actuation of the pilot control device.

The pilot control device is installed separately from the pump (for example in the driver's cabin) and connected to the pump by two hydraulic control lines via ports **Ps** and **Y**. A suitable pilot control device must be ordered separately and is not included in the scope of delivery.

Note: Rotary inch valves, see page 63.

▼ **Circuit diagram DA1D7/DA2D7<sup>1)</sup>**

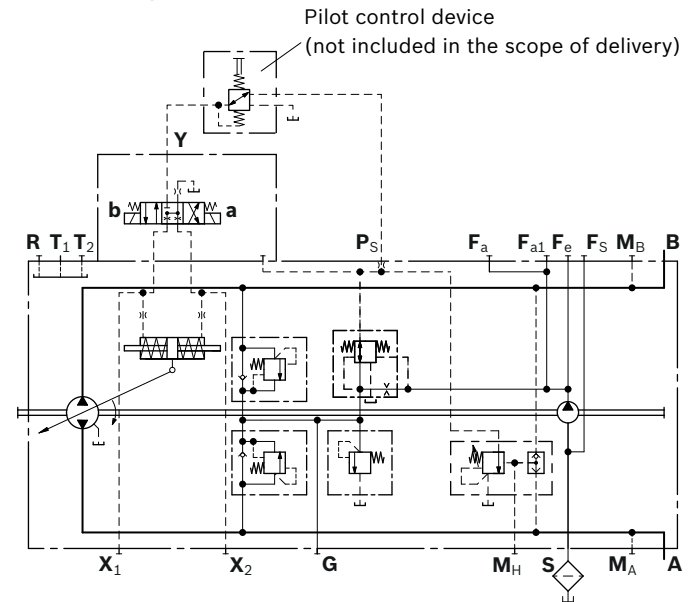

1) Size 28 without port **Fa1** and **Fs**

**DA..8 – DA control valve, fixed setting and brake inch valve mounted**

Only for pumps with DA control module

- ▶ Version with throttle valve size 28, 40, 56, 71
- ▶ Version with pressure reducing valve size 90, 125

Permits reduction of the pilot pressure, independently of the drive speed via hydraulic control (port Z).

Control at port Z by means of brake fluid based on mineral oil.

▼ **Circuit diagram DA1D8/DA2D8 with throttle valve<sup>1)</sup>**

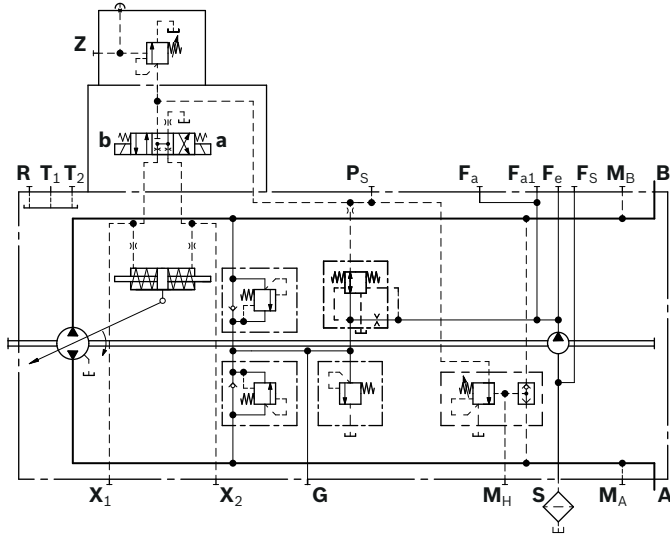

▼ **Circuit diagram DA1D8/DA2D8 with pressure reducing valve<sup>1)</sup>**

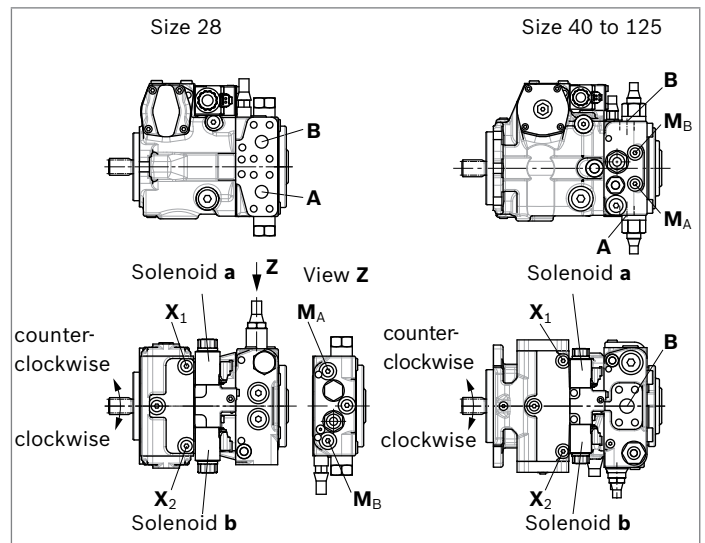
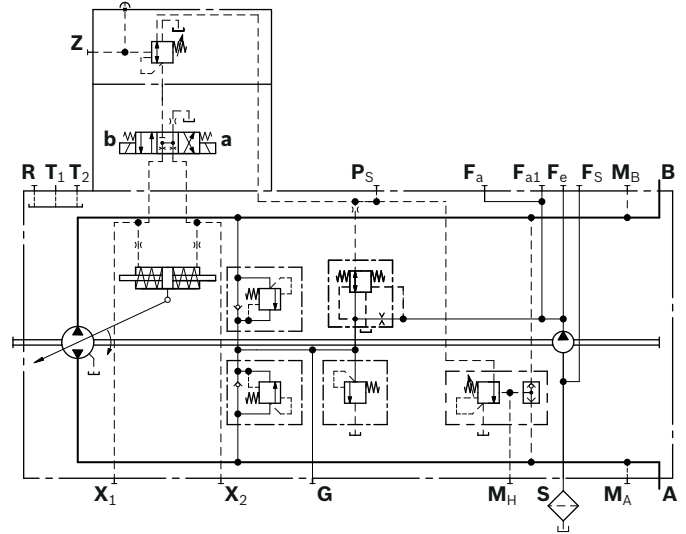

Correlation of direction of rotation, control and flow direction									
Direction of rotation	clockwise				counter-clockwise				
Size	28 to 56		71 to 125		28 to 56		71 to 125		
Actuation of solenoid	a	b	a	b	a	b	a	b	
Control pressure	X <sub>2</sub>	X <sub>1</sub>	X <sub>2</sub>	X <sub>1</sub>	X <sub>2</sub>	X <sub>1</sub>	X <sub>2</sub>	X <sub>1</sub>	
Flow direction	B to A	A to B	A to B	B to A	A to B	B to A	B to A	A to B	
Working pressure	M <sub>A</sub>	M <sub>B</sub>	M <sub>B</sub>	M <sub>A</sub>	M <sub>B</sub>	M <sub>A</sub>	M <sub>A</sub>	M <sub>B</sub>	

<sup>1)</sup> Size 28 without port F<sub>a1</sub> and F<sub>S</sub>

## ET – Electric control, direct operated

The output flow of the pump is infinitely variable between 0 to 100%. Depending on the preselected current **I** at solenoids **a** and **b** of the pressure reducing valves, the stroking cylinder of the pump is proportionally supplied with control pressure. The two control pressures **X<sub>1</sub>** and **X<sub>2</sub>** can be controlled independently. The pump displacement that arises at a certain control current is dependent on the speed and working pressure of the pump. A different flow direction is associated with each pressure reducing valve. Maximum permissible control pressure **P<sub>S</sub>**: 580 psi (40 bar).

Technical data, solenoid	ET5	ET6
Voltage	12 V (±20%)	24 V (±20%)
Current limit	1.54 A	0.77 A
Nominal resistance (at 68 °F (20 °C))	5.5 Ω	22.7 Ω
Dither		
Frequency	100 Hz	100 Hz
Minimum oscillation range <sup>1)</sup>	240 mA	120 mA
Duty cycle	100%	100%
Type of protection: see connector version page 62		

### ▼ Standard version<sup>1)</sup>

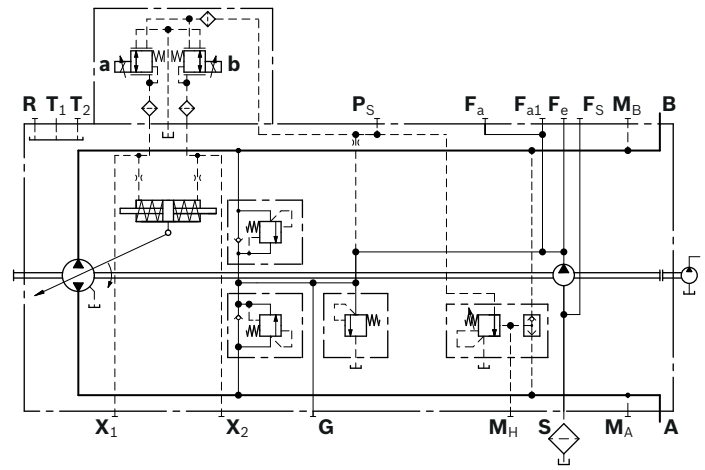

Correlation of direction of rotation, control and flow direction									
Direction of rotation	clockwise				counter-clockwise				
Size	28 to 56		71		28 to 56		71		
Actuation of solenoid	<b>a</b>	<b>b</b>	<b>a</b>	<b>b</b>	<b>a</b>	<b>b</b>	<b>a</b>	<b>b</b>	<b>b</b>
Control pressure	<b>X<sub>1</sub></b>	<b>X<sub>2</sub></b>	<b>X<sub>1</sub></b>	<b>X<sub>2</sub></b>	<b>X<sub>1</sub></b>	<b>X<sub>2</sub></b>	<b>X<sub>1</sub></b>	<b>X<sub>2</sub></b>	<b>X<sub>2</sub></b>
Flow direction	<b>A to B</b>	<b>B to A</b>	<b>B to A</b>	<b>A to B</b>	<b>B to A</b>	<b>A to B</b>	<b>A to B</b>	<b>A to B</b>	<b>B to A</b>
Working pressure	<b>M<sub>B</sub></b>	<b>M<sub>A</sub></b>	<b>M<sub>A</sub></b>	<b>M<sub>B</sub></b>	<b>M<sub>A</sub></b>	<b>M<sub>B</sub></b>	<b>M<sub>B</sub></b>	<b>M<sub>B</sub></b>	<b>M<sub>A</sub></b>

1) Size 28 without port **F<sub>a1</sub>** and **F<sub>s</sub>**

**Dimensions, size 28**

**NV – Version without control module**

Standard: SAE working port **A** and **B**, same side right, suction port **S** bottom (60)

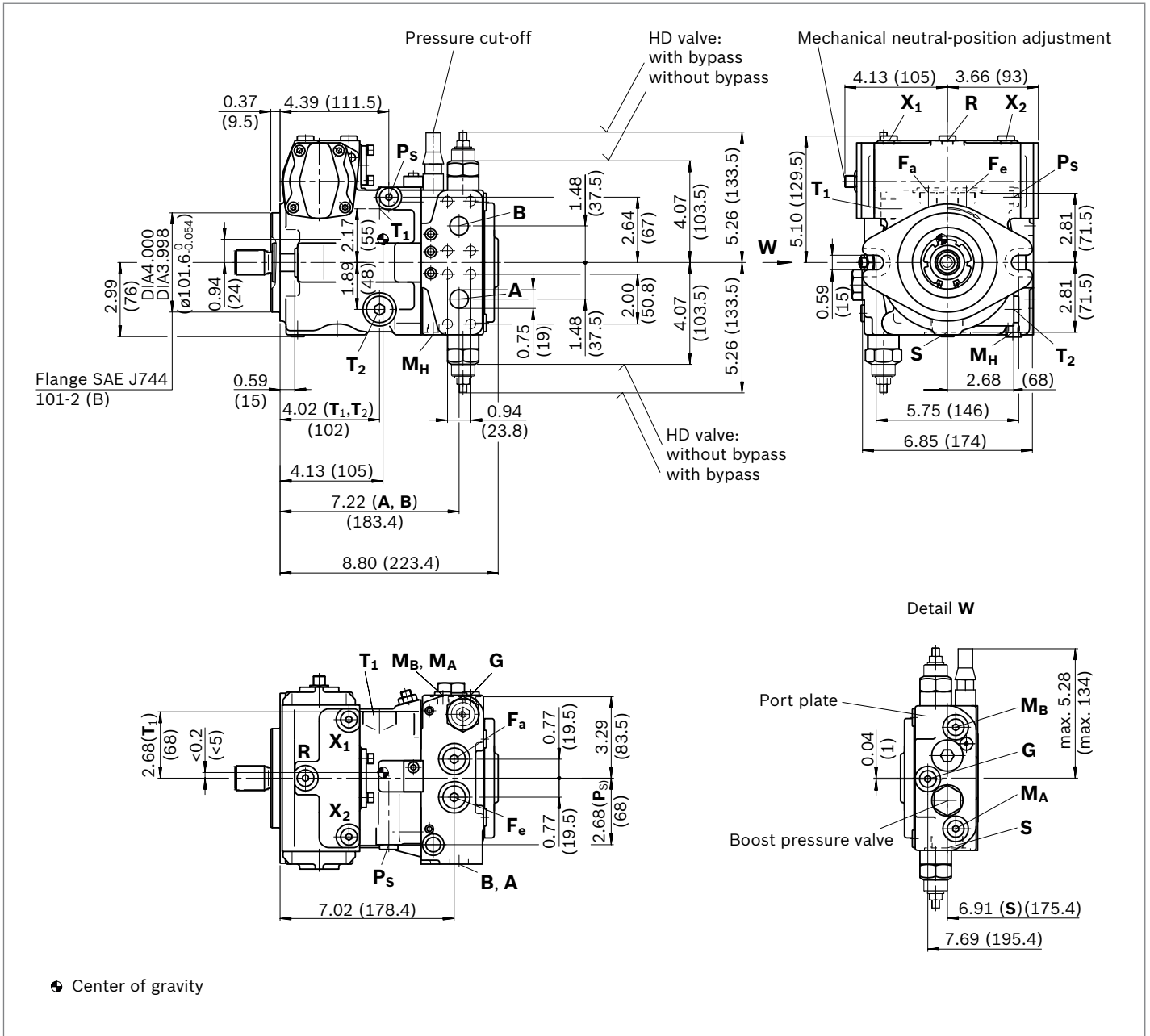

▼ **Splined shaft ANSI B92.1a**

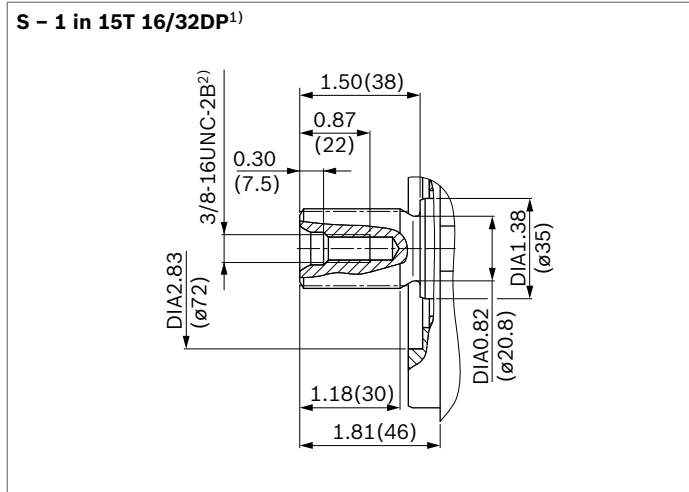

Ports	Standard	Size	$p_{max}$ [psi (bar)] <sup>3)</sup>	State <sup>8)</sup>
<b>A, B</b>	Working port Fastening thread	SAEJ518 <sup>4)</sup> ISO 68	3/4 in 3/8 in -16 UNC-2B; 0.67 (17) deep	6500 (450) O
<b>S</b>	Suction port	ISO 11926 <sup>7)</sup>	1 5/16 in -12 UN-2B; 0.79 (20) deep	75 (5) O <sup>5)</sup>
<b>T<sub>1</sub></b>	Drain port	ISO 11926 <sup>7)</sup>	7/8 in -14 UNF-2B; 0.67 (17) deep	45 (3) O <sup>6)</sup>
<b>T<sub>2</sub></b>	Drain port	ISO 11926 <sup>7)</sup>	7/8 in -14 UNF-2B; 0.67 (17) deep	45 (3) X <sup>6)</sup>
<b>R</b>	Air bleed port	ISO 11926 <sup>7)</sup>	7/16 in -20 UNF-2B; 0.47 (12) deep	45 (3) X
<b>X<sub>1</sub>, X<sub>2</sub></b>	Control pressure port (upstream of orifice)	ISO 11926 <sup>7)</sup>	7/16 in -20 UNF-2B; 0.47 (12) deep	580 (40) X
<b>G</b>	Boost pressure port inlet	ISO 11926 <sup>7)</sup>	7/16 in -20 UNF-2B; 0.47 (12) deep	580 (40) X
<b>P<sub>s</sub></b>	Pilot pressure port	ISO 11926 <sup>7)</sup>	9/16 in -18 UNF-2B; 0.51 (13) deep	580 (40) X
<b>M<sub>A</sub>, M<sub>B</sub></b>	Measuring port pressure A, B	ISO 11926 <sup>7)</sup>	7/16 in -20 UNF-2B; 0.47 (12) deep	6500 (450) X
<b>M<sub>H</sub></b>	Measuring port, high pressure	ISO 11926 <sup>7)</sup>	7/16 in -20 UNF-2B; 0.47 (12) deep	6500 (450) X
<b>F<sub>a</sub></b>	Boost pressure port inlet	ISO 11926 <sup>7)</sup>	3/4 in -16 UNF-2B; 0.59 (15) deep	580 (40) X
<b>F<sub>e</sub></b>	Boost pressure port outlet	ISO 11926 <sup>7)</sup>	3/4 in -16 UNF-2B; 0.59 (15) deep	580 (40) X
<b>Z</b>	Pilot pressure port (inch signal DA..8 only)	DIN 3852 <sup>7)</sup>	M10 x 1; 0.31 (8) deep	580 (40) X

1) Involute spline according to ANSI B92.1a, 30° pressure angle, flat root, side fit, tolerance class 5  
 2) Thread according to ASME B1.1  
 3) Depending on the application, momentary pressure peaks can occur. Keep this in mind when selecting measuring devices and fittings.  
 4) Only dimensions according to SAE J518, metric fastening thread is a deviation from the standard.

5) Plugged for external boost pressure supply.  
 6) Depending on installation position, **T<sub>1</sub>** or **T<sub>2</sub>** must be connected (see also installation instructions on page 65).  
 7) The countersink can be deeper than as specified in the standard.  
 8) O = Must be connected (plugged when delivered)  
 X = Plugged (observe installation instructions)



▼ **HW** – Proportional control, hydraulic, mechanical servo

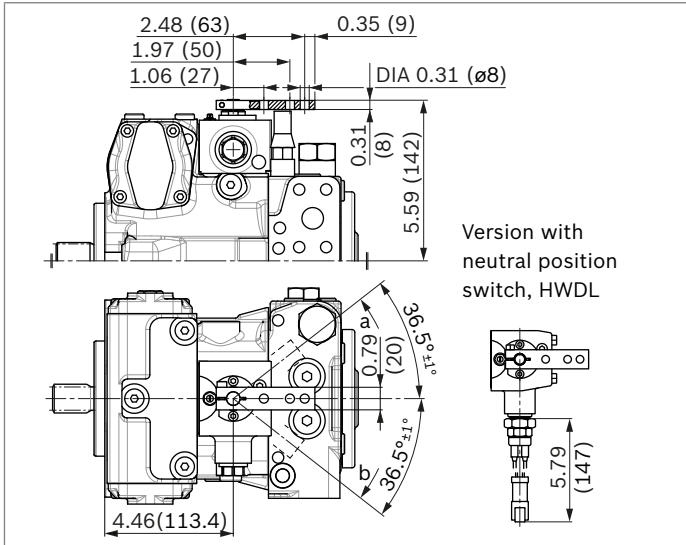

▼ **EP** – Proportional control, electric

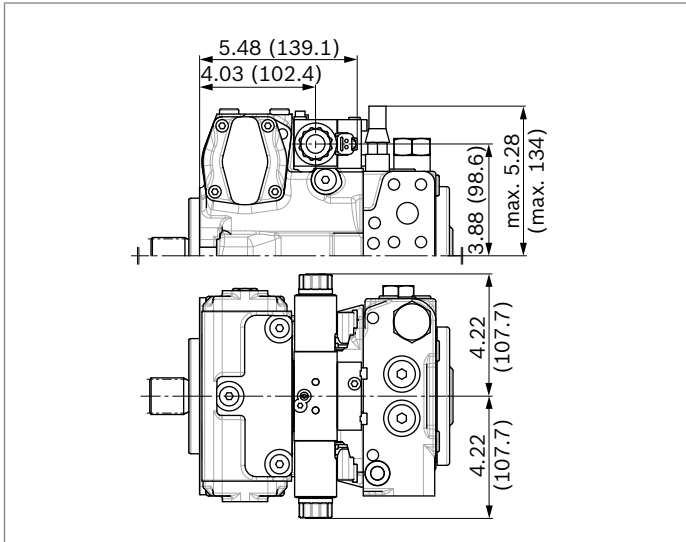

▼ **EZ** – Two-point control, electric

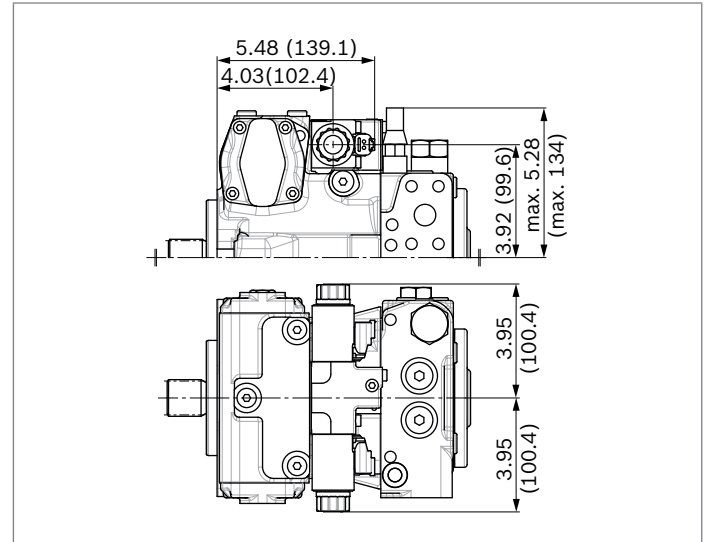

**DA control valve**

▼ **DA..2** – fixed setting

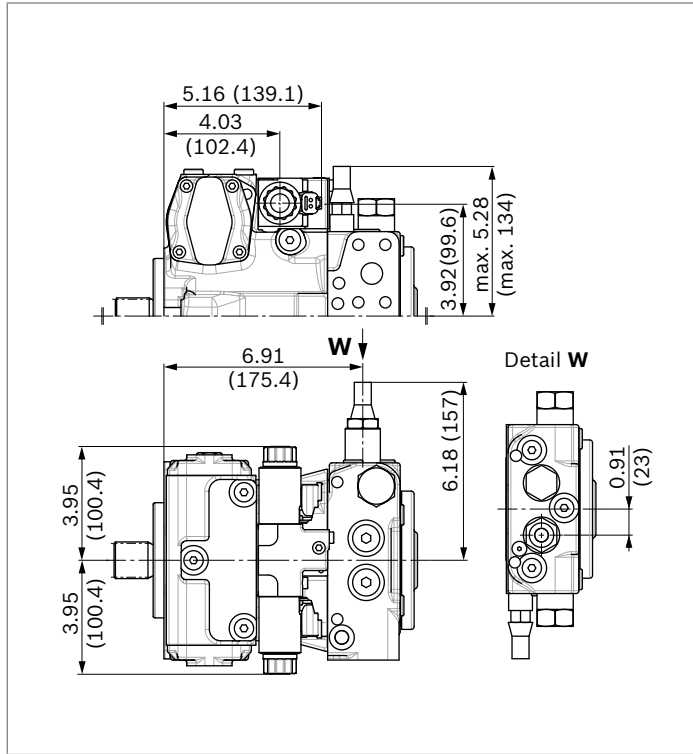

▼ **DA..3** – Mechanically adjustable with position lever

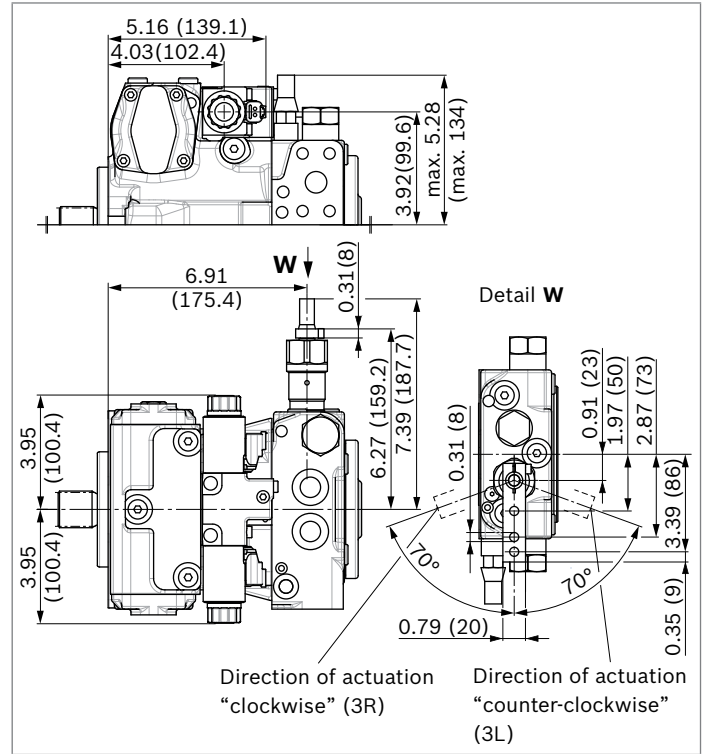

▼ **DA..8** – Fixed setting and inch valve mounted

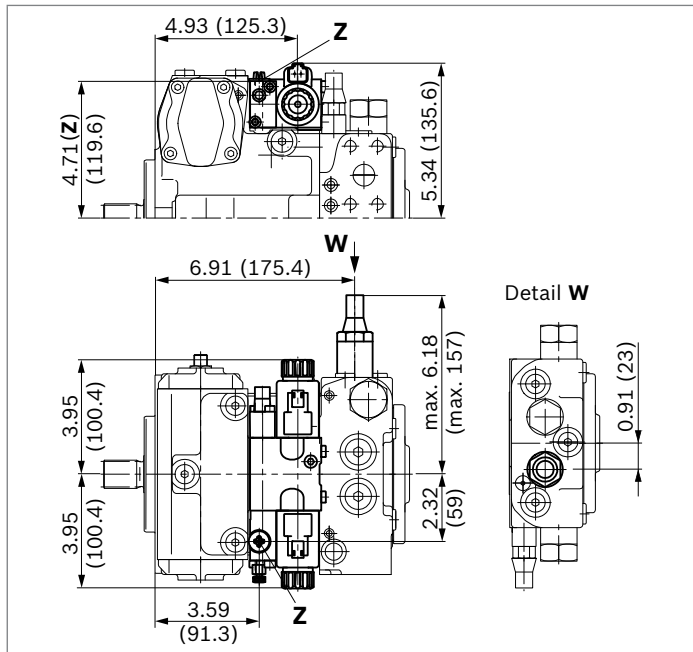

**Dimensions, size 40**

**NV – Version without control module**

Standard: SAE working port **A** and **B** top and bottom, suction port **S** bottom (52)

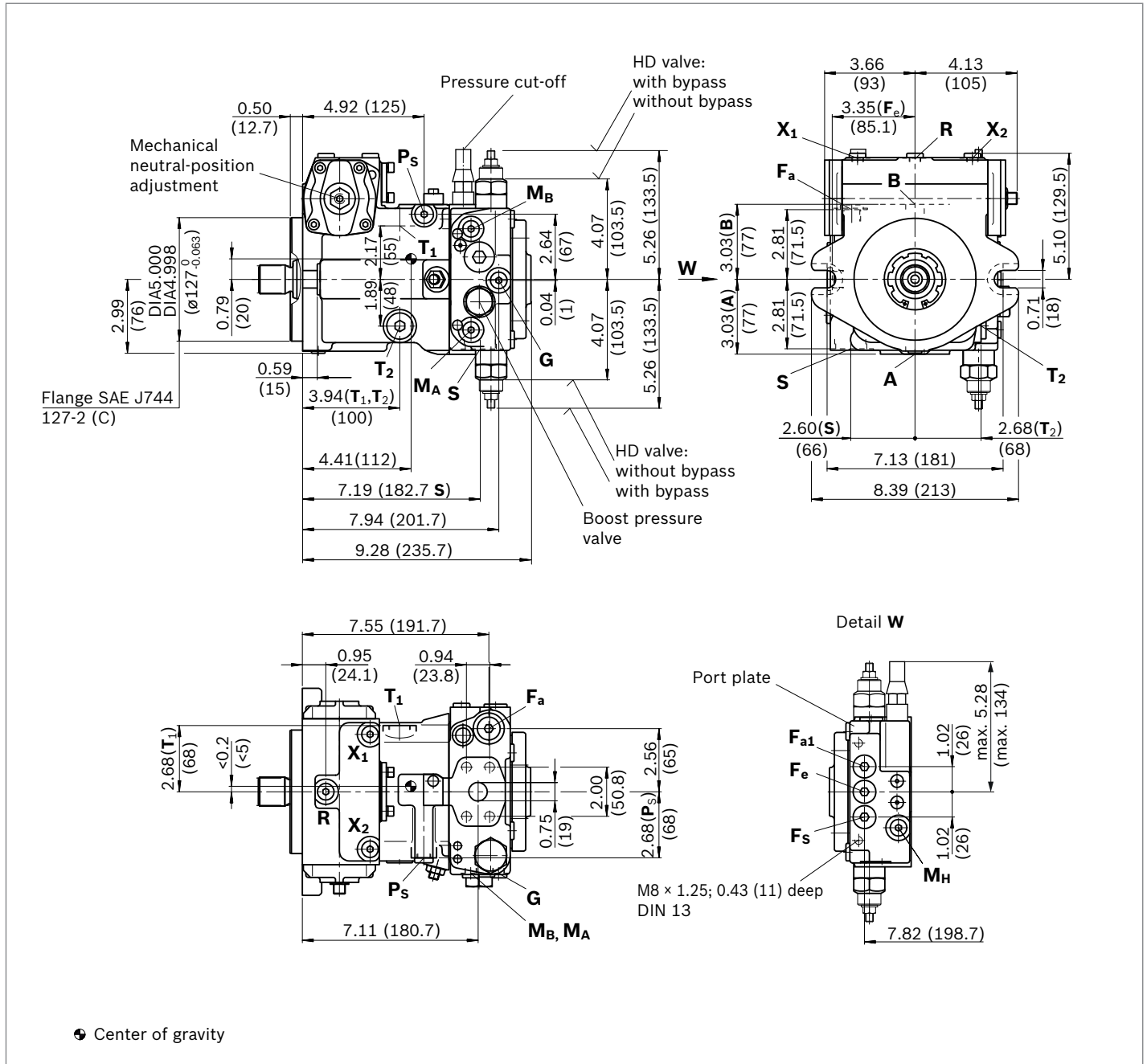

**Notice**

Option: SAE working port **A** and **B** top and bottom, suction port **S** top (53), port plate 52 rotated through 180°, installation drawing on request

▼ **Splined shaft ANSI B92.1a**

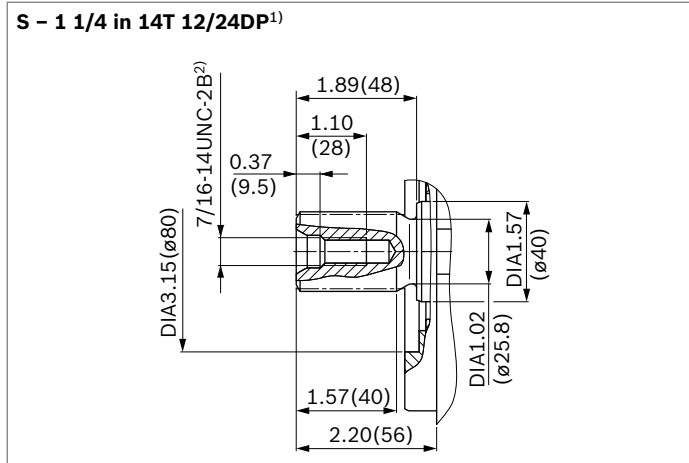

▼ **Splined shaft ANSI B92.1a**

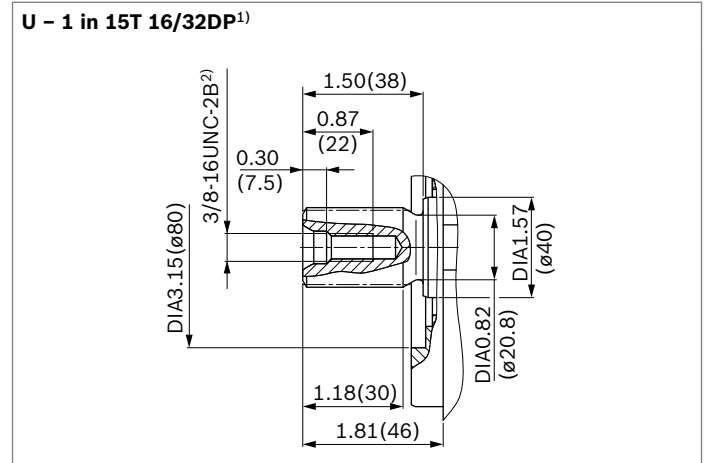

Ports	Standard	Size	$p_{max}$ [psi (bar)] <sup>3)</sup>	State <sup>8)</sup>
<b>A, B</b>	Working port Fastening thread	SAEJ518 <sup>4)</sup> ASME B1.1	3/4 in 3/8 in -16 UNC-2B; 0.67 (17) deep	6500 (450) O
<b>S</b>	Suction port	ISO 11926 <sup>7)</sup>	1 5/16 in -12 UN-2B; 0.79 (20) deep	75 (5) O <sup>5)</sup>
<b>T<sub>1</sub></b>	Drain port	ISO 11926 <sup>7)</sup>	7/8 in -14 UNF-2B; 0.67 (17) deep	45 (3) O <sup>6)</sup>
<b>T<sub>2</sub></b>	Drain port	ISO 11926 <sup>7)</sup>	7/8 in -14 UNF-2B; 0.67 (17) deep	45 (3) X <sup>6)</sup>
<b>R</b>	Air bleed port	ISO 11926 <sup>7)</sup>	7/16 in -20 UNF-2B; 0.47 (12) deep	45 (3) X
<b>X<sub>1</sub>, X<sub>2</sub></b>	Control pressure port (upstream of orifice)	ISO 11926 <sup>7)</sup>	7/16 in -20 UNF-2B; 0.47 (12) deep	580 (40) X
<b>G</b>	Boost pressure port inlet	ISO 11926 <sup>7)</sup>	7/16 in -20 UNF-2B; 0.47 (12) deep	580 (40) X
<b>P<sub>s</sub></b>	Pilot pressure port	ISO 11926 <sup>7)</sup>	9/16 in -18 UNF-2B; 0.51 (13) deep	580 (40) X
<b>M<sub>A</sub>, M<sub>B</sub></b>	Measuring port pressure A, B	ISO 11926 <sup>7)</sup>	7/16 in -20 UNF-2B; 0.47 (12) deep	6500 (450) X
<b>M<sub>H</sub></b>	Measuring port, high pressure	ISO 11926 <sup>7)</sup>	7/16 in -20 UNF-2B; 0.47 (12) deep	6500 (450) X
<b>F<sub>a</sub></b>	Boost pressure port inlet	ISO 11926 <sup>7)</sup>	3/4 in -16 UNF-2B; 0.51 (13) deep	580 (40) X
<b>F<sub>a1</sub></b>	Boost pressure port inlet (attachment filter)	DIN 3852 <sup>7)</sup>	M18 x 1.5; 0.47 (12) deep	580 (40) X
<b>F<sub>e</sub></b>	Boost pressure port outlet	DIN 3852 <sup>7)</sup>	M18 x 1.5; 0.47 (12) deep	580 (40) X
<b>F<sub>s</sub></b>	Line from filter to suction port (cold start)	DIN 3852 <sup>7)</sup>	M18 x 1.5; 0.47 (12) deep	580 (40) X
<b>Z</b>	Pilot pressure port (inch signal DA..8 only)	DIN 3852 <sup>7)</sup>	M10 x 1; 0.31 (8) deep	580 (40) X

1) Involute spline according to ANSI B92.1a, 30° pressure angle, flat root, side fit, tolerance class 5  
2) Thread according to ASME B1.1  
3) Depending on the application, momentary pressure peaks can occur. Keep this in mind when selecting measuring devices and fittings.  
4) Only dimensions according to SAE J518, metric fastening thread is a deviation from the standard.

5) Plugged for external boost pressure supply.  
6) Depending on installation position, **T<sub>1</sub>** or **T<sub>2</sub>** must be connected (see also installation instructions on page 65).  
7) The countersink can be deeper than as specified in the standard.  
8) O = Must be connected (plugged when delivered)  
X = Plugged (in normal operation)

▼ **HW** – Proportional control, hydraulic, mechanical servo

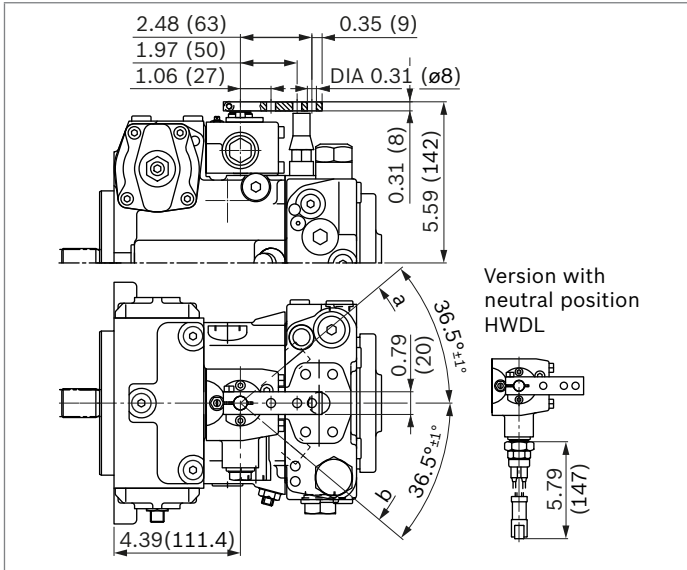

▼ **EP** – Proportional control, electric

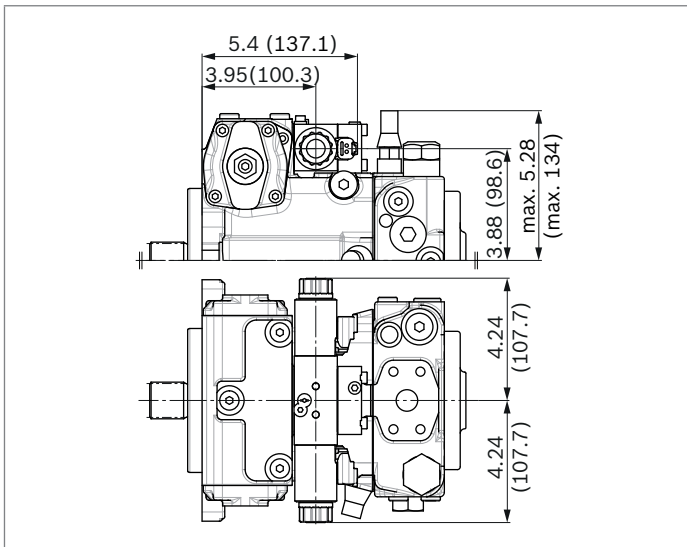

▼ **EZ** – Two-point control, electric

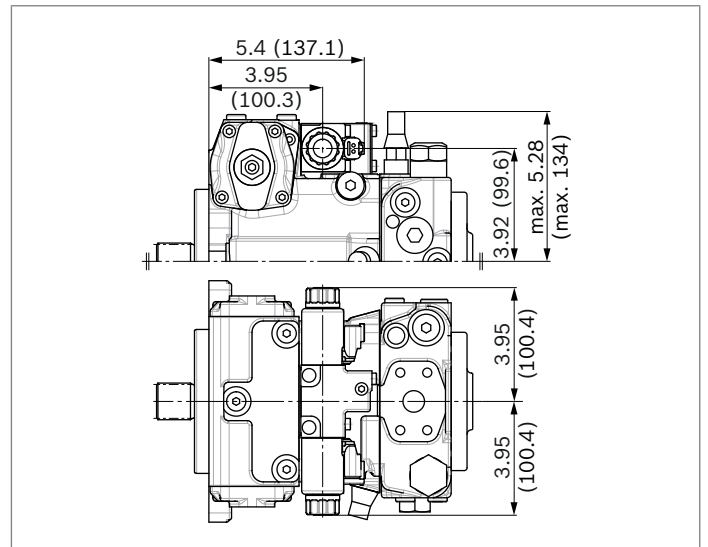

**DA control valve**

▼ **DA..2** – Fixed setting

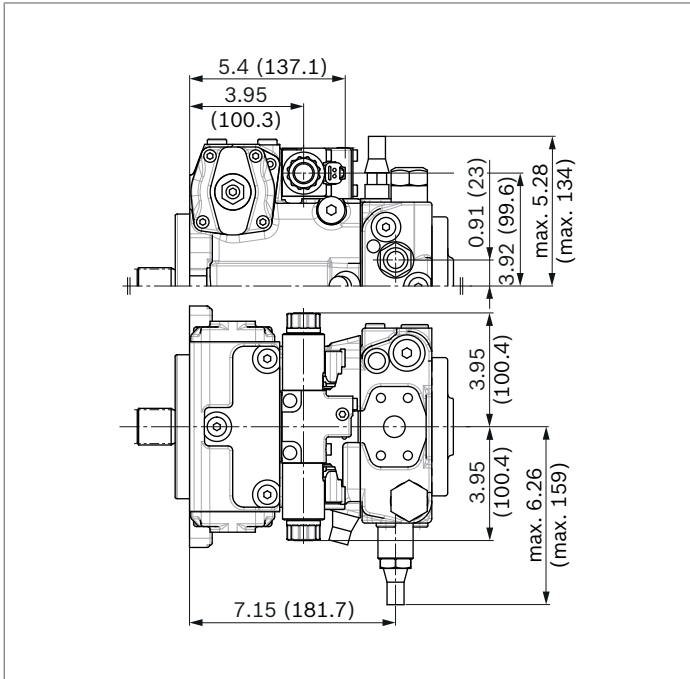

▼ **DA..3** – Mechanically adjustable with position lever

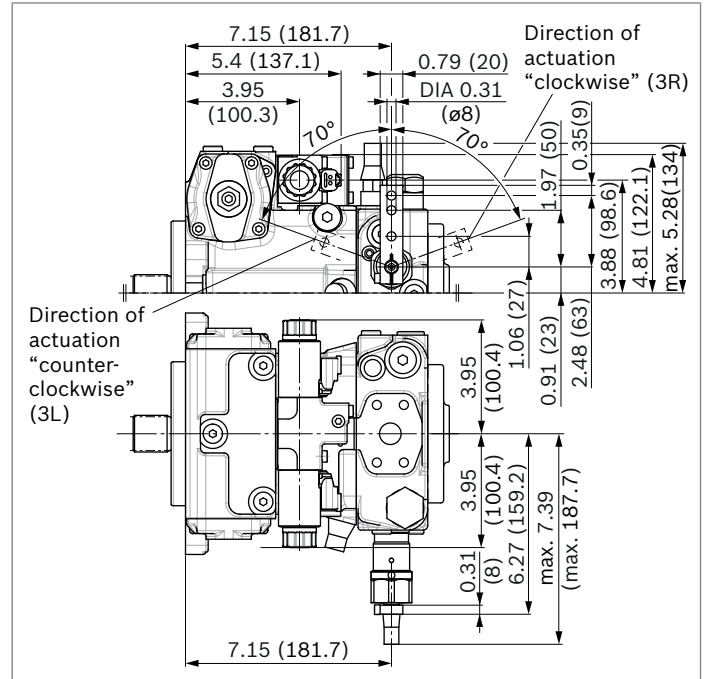

▼ **DA..8** – Fixed setting and inch valve mounted

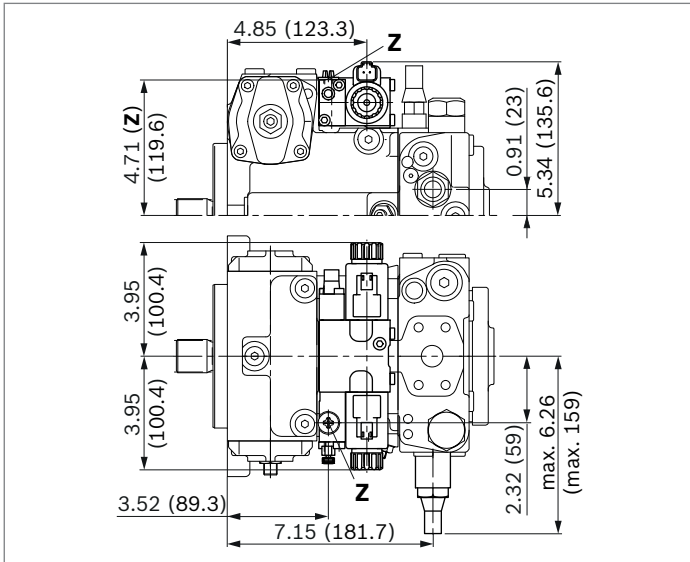

**Dimensions, size 56**

**NV – Version without control module**

Standard: SAE working port **A** and **B** top and bottom, suction port **S** bottom (52)

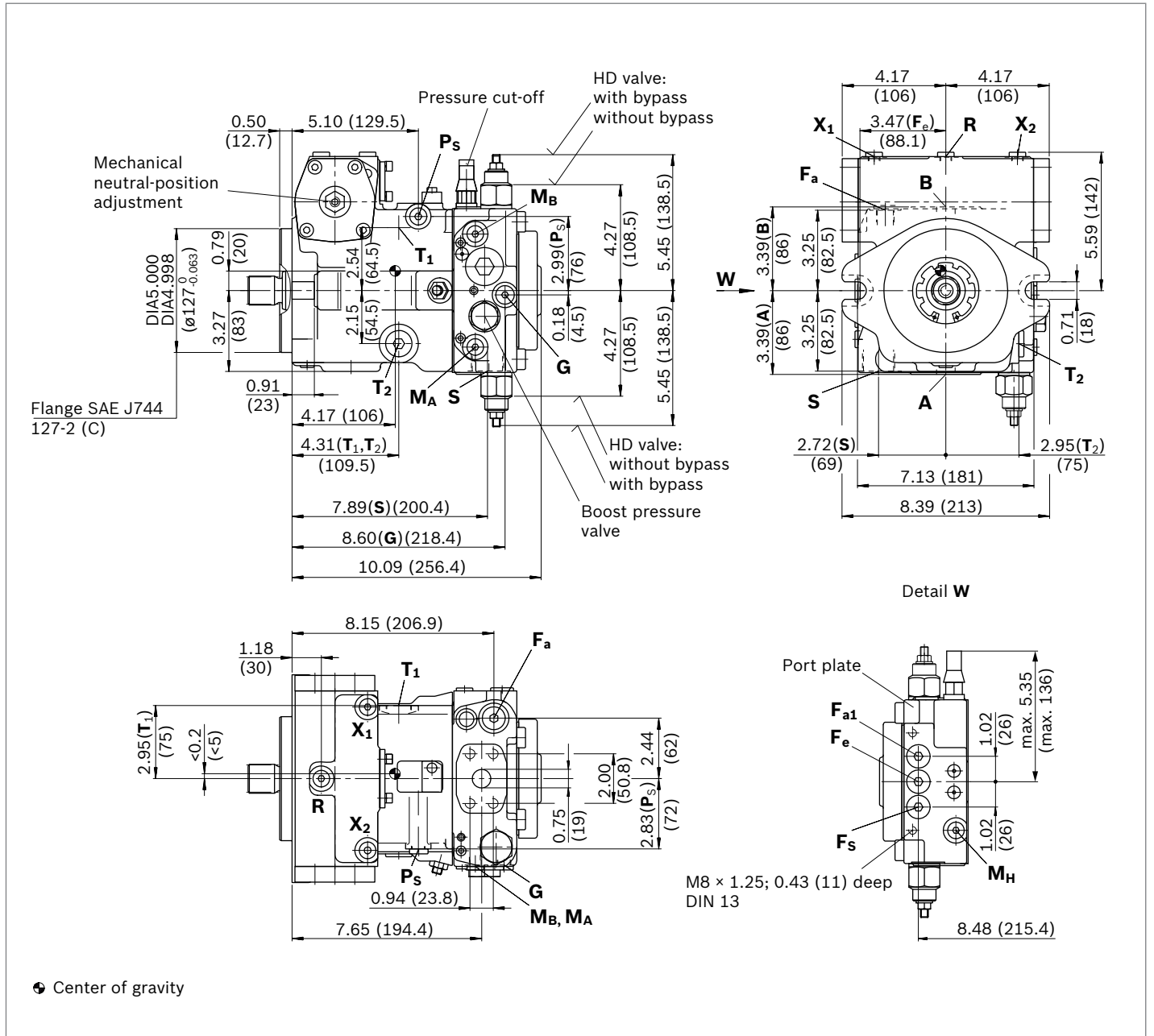

**Notice**

Option: SAE working port **A** and **B** top and bottom, suction port **S** top (53), port plate 52 rotated through 180°, installation drawing on request

▼ **Splined shaft ANSI B92.1a**

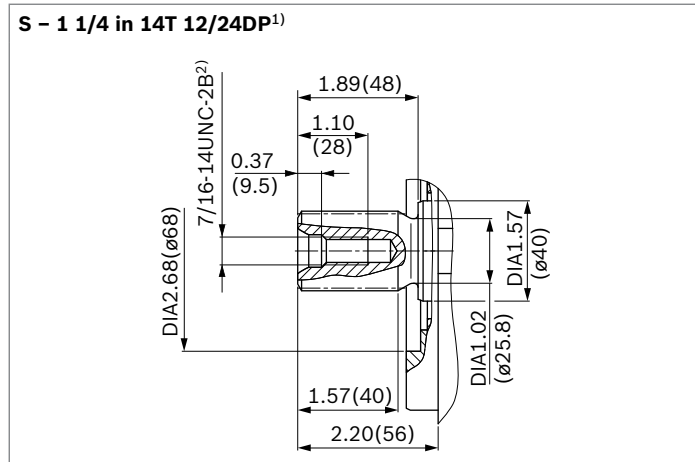

▼ **Splined shaft ANSI B92.1a**

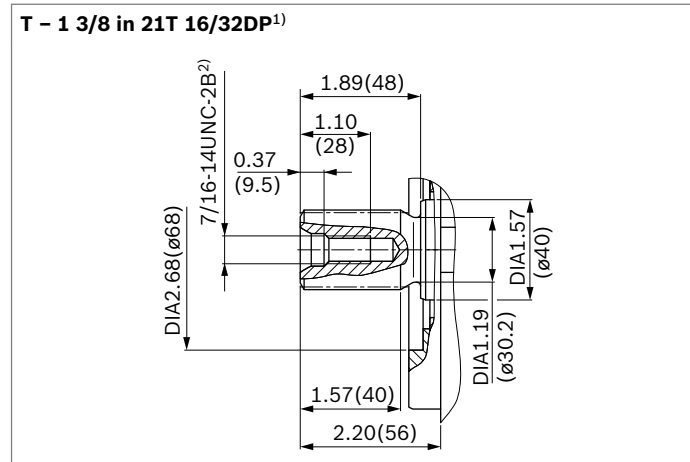

Ports	Standard	Size	$p_{max}$ [psi (bar)] <sup>3)</sup>	State <sup>9)</sup>
<b>A, B</b>	Working port Fastening thread	SAEJ518 <sup>4)</sup> ASME B1.1	3/4 in 3/8 in -16 UNC-2B; 0.67 (17) deep	6500 (450) O
<b>S</b>	Suction port	ISO 11926 <sup>7)</sup>	1 5/16 in -12 UN-2B; 0.79 (20) deep	75 (5) O <sup>5)</sup>
<b>T<sub>1</sub></b>	Drain port	ISO 11926 <sup>7)</sup>	1 1/16 in -12 UN-2B; 0.79 (20) deep	45 (3) O <sup>6)</sup>
<b>T<sub>2</sub></b>	Drain port	ISO 11926 <sup>7)</sup>	1 1/16 in -12 UN-2B; 0.79 (20) deep	45 (3) X <sup>6)</sup>
<b>R</b>	Air bleed port	ISO 11926 <sup>7)</sup>	7/16 in -20 UNF-2B; 0.47 (12) deep	45 (3) X
<b>X<sub>1</sub>, X<sub>2</sub></b>	Control pressure port (upstream of orifice)	ISO 11926 <sup>7)</sup>	7/16 in -20 UNF-2B; 0.47 (12) deep	580 (40) X
<b>X<sub>1</sub>, X<sub>2</sub></b>	Control pressure port (upstream of orifice, DG only)	ISO 11926 <sup>7)</sup>	7/16 in -20 UNF-2B; 0.47 (12) deep	580 (40) O
<b>X<sub>3</sub>, X<sub>4</sub><sup>B)</sup></b>	Stroking chamber pressure port	ISO 11926 <sup>7)</sup>	7/16 in -20 UNF-2B; 0.47 (12) deep	580 (40) X
<b>G</b>	Boost pressure port inlet	ISO 11926 <sup>7)</sup>	9/16 in -18 UNF-2B; 0.51 (13) deep	580 (40) X
<b>P<sub>S</sub></b>	Pilot pressure port	ISO 11926 <sup>7)</sup>	9/16 in -18 UNF-2B; 0.51 (13) deep	580 (40) X
<b>M<sub>A</sub>, M<sub>B</sub></b>	Measuring port pressure A, B	ISO 11926 <sup>7)</sup>	7/16 in -20 UNF-2B; 0.47 (12) deep	6500 (450) X
<b>M<sub>H</sub></b>	Measuring port, high pressure	ISO 11926 <sup>7)</sup>	7/16 in -20 UNF-2B; 0.47 (12) deep	6500 (450) X
<b>F<sub>a</sub></b>	Boost pressure port inlet	ISO 11926 <sup>7)</sup>	3/4 in -16 UNF-2B; 0.59 (15) deep	580 (40) X
<b>F<sub>a1</sub></b>	Boost pressure port inlet (attachment filter)	DIN 3852 <sup>7)</sup>	M18 x 1.5; 0.47 (12) deep	580 (40) X
<b>F<sub>e</sub></b>	Boost pressure port outlet	DIN 3852 <sup>7)</sup>	M18 x 1.5; 0.47 (12) deep	580 (40) X
<b>F<sub>S</sub></b>	Line from filter to suction port (cold start)	DIN 3852 <sup>7)</sup>	M18 x 1.5; 0.47 (12) deep	580 (40) X
<b>Y<sub>1</sub>, Y<sub>2</sub></b>	Pilot pressure port (pilot signal HD only)	ISO 11926 <sup>7)</sup>	9/16 in -18 UNF-2B; 0.51 (13) deep	580 (40) O
<b>Z</b>	Pilot pressure port (inch signal DA..8 only)	DIN 3852 <sup>7)</sup>	M10 x 1; 0.31 (8) deep	580 (40) X

1) Involute spline according to ANSI B92.1a, 30° pressure angle, flat root, side fit, tolerance class 5  
 2) Thread according to ASME B1.1  
 3) Depending on the application, momentary pressure peaks can occur. Keep this in mind when selecting measuring devices and fittings.  
 4) Only dimensions according to SAE J518, metric fastening thread is a deviation from the standard.

5) Plugged for external boost pressure supply.  
 6) Depending on installation position, **T<sub>1</sub>** or **T<sub>2</sub>** must be connected (see also installation instructions on page 65).  
 7) The countersink can be deeper than as specified in the standard.  
 8) Optional, see page 55  
 9) O = Must be connected (plugged when delivered)  
 X = Plugged (in normal operation)



▼ **HD** – Proportional control, hydraulic, pilot-pressure related

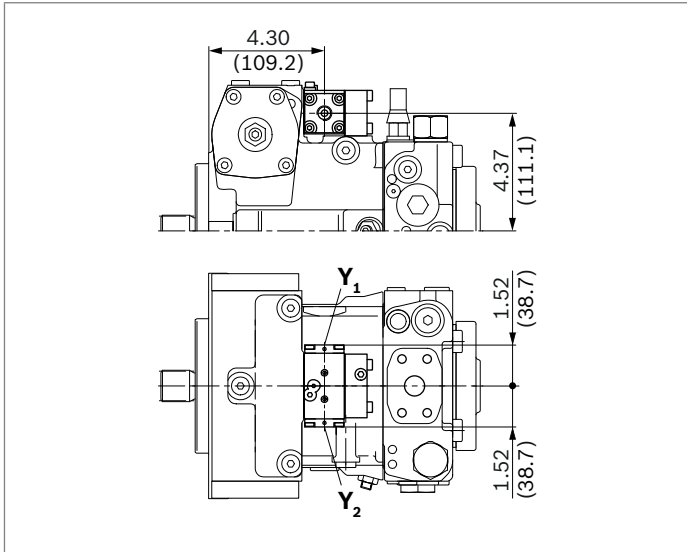

▼ **HW** – Proportional control, hydraulic, mechanical servo

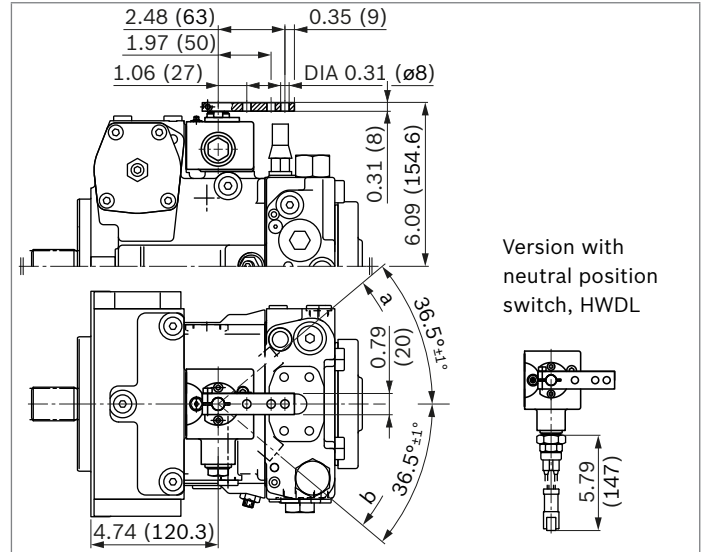

▼ **EP** – Proportional control, electric

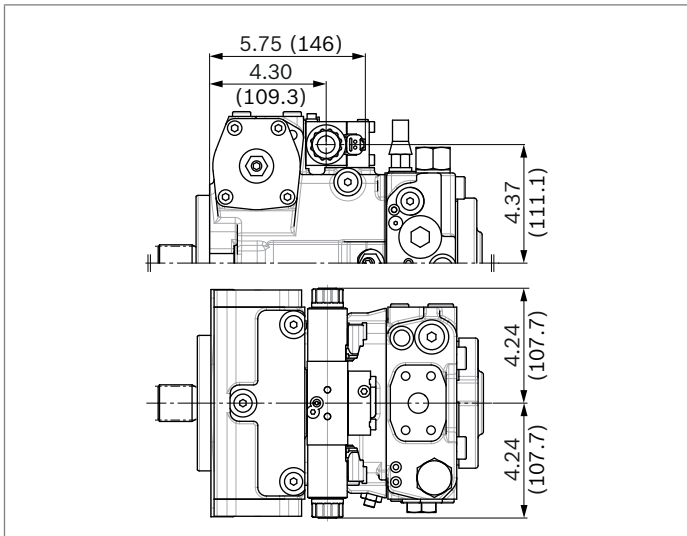

▼ **EZ** – Two-point control, electric

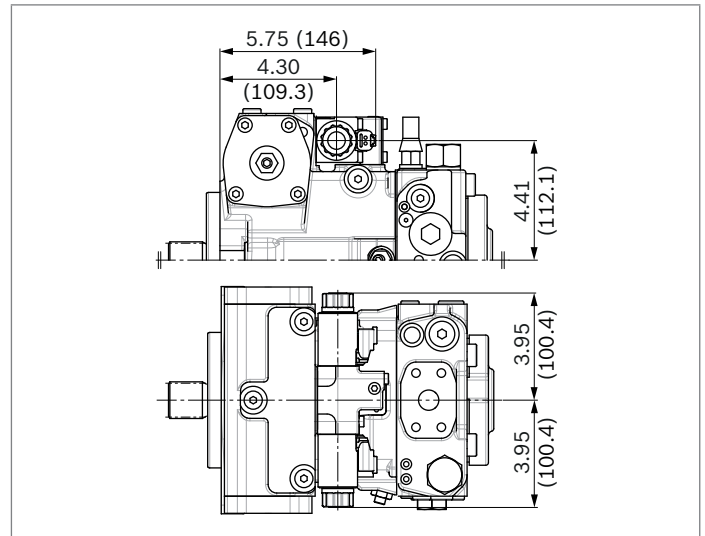

▼ **DG** – Hydraulic control, direct operated

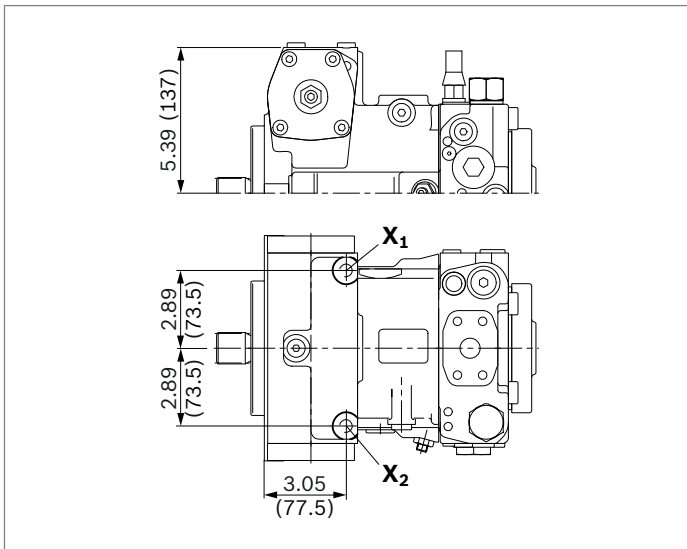

**DA control valve**

▼ **DA..2** – Fixed setting

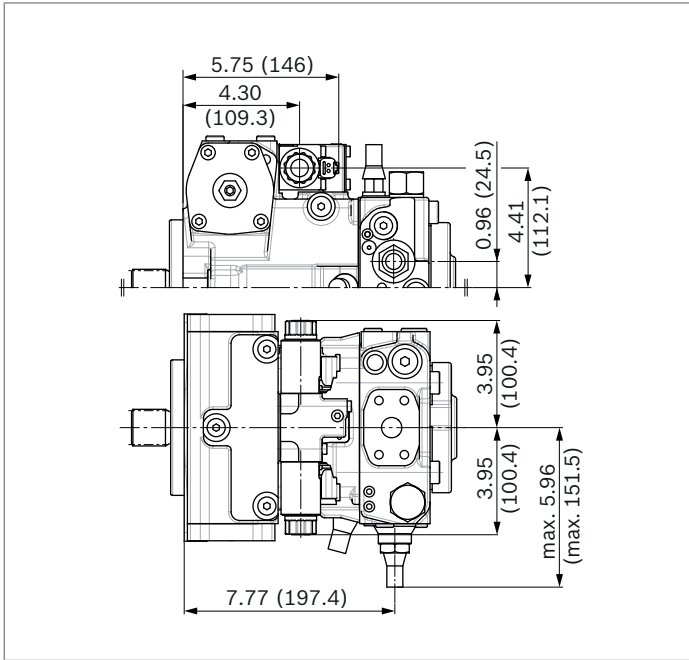

▼ **DA..3** – Mechanically adjustable with position lever

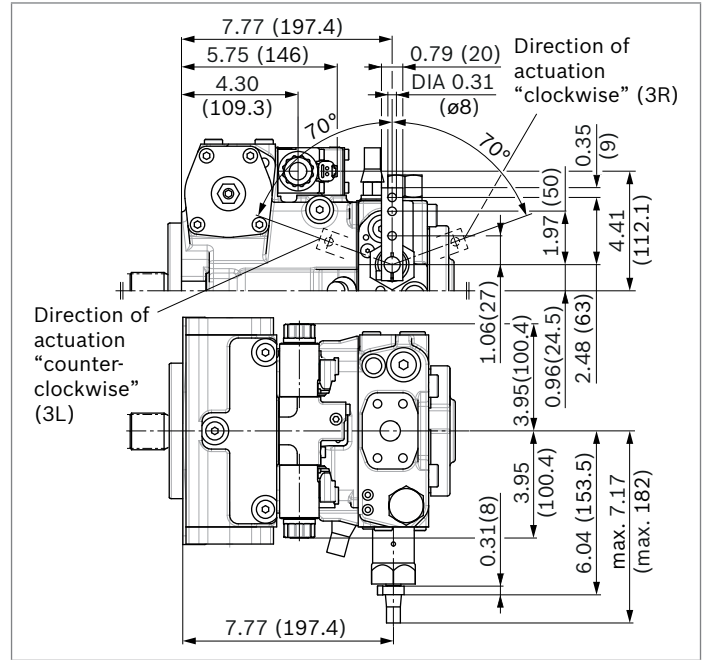

▼ **DA..8** – Fixed setting and inch valve mounted

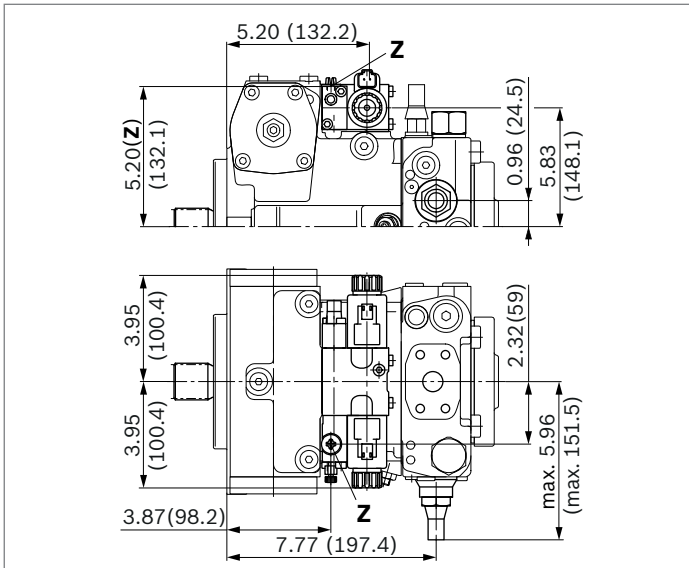

### Dimensions, size 71

#### NV – Version without control module

Standard: SAE working port **A** and **B** top and bottom, suction port **S** bottom (52)

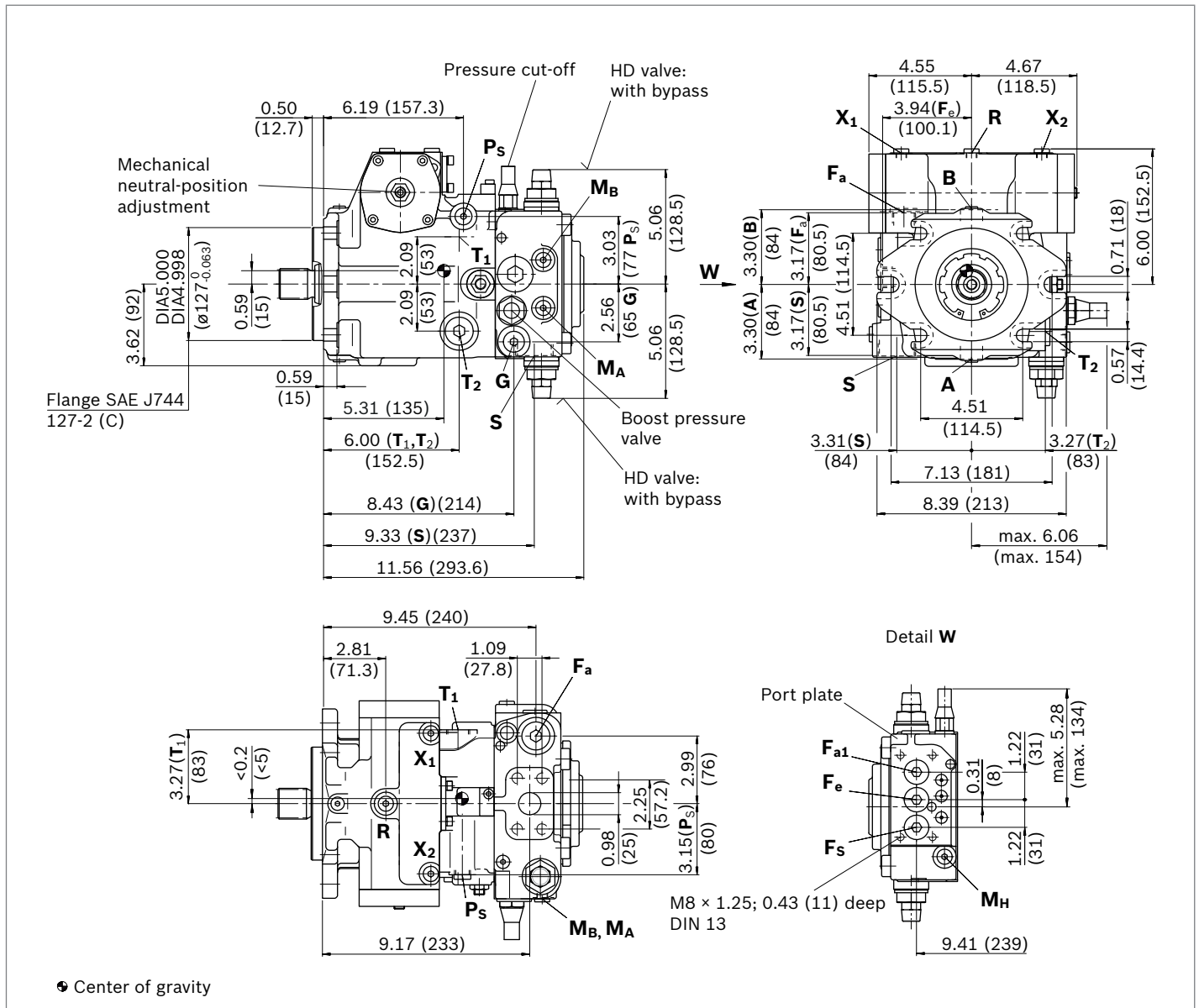

**NV – Version without control module**

Standard: SAE working port **A** and **B**, same side left, suction port **S** bottom (60)

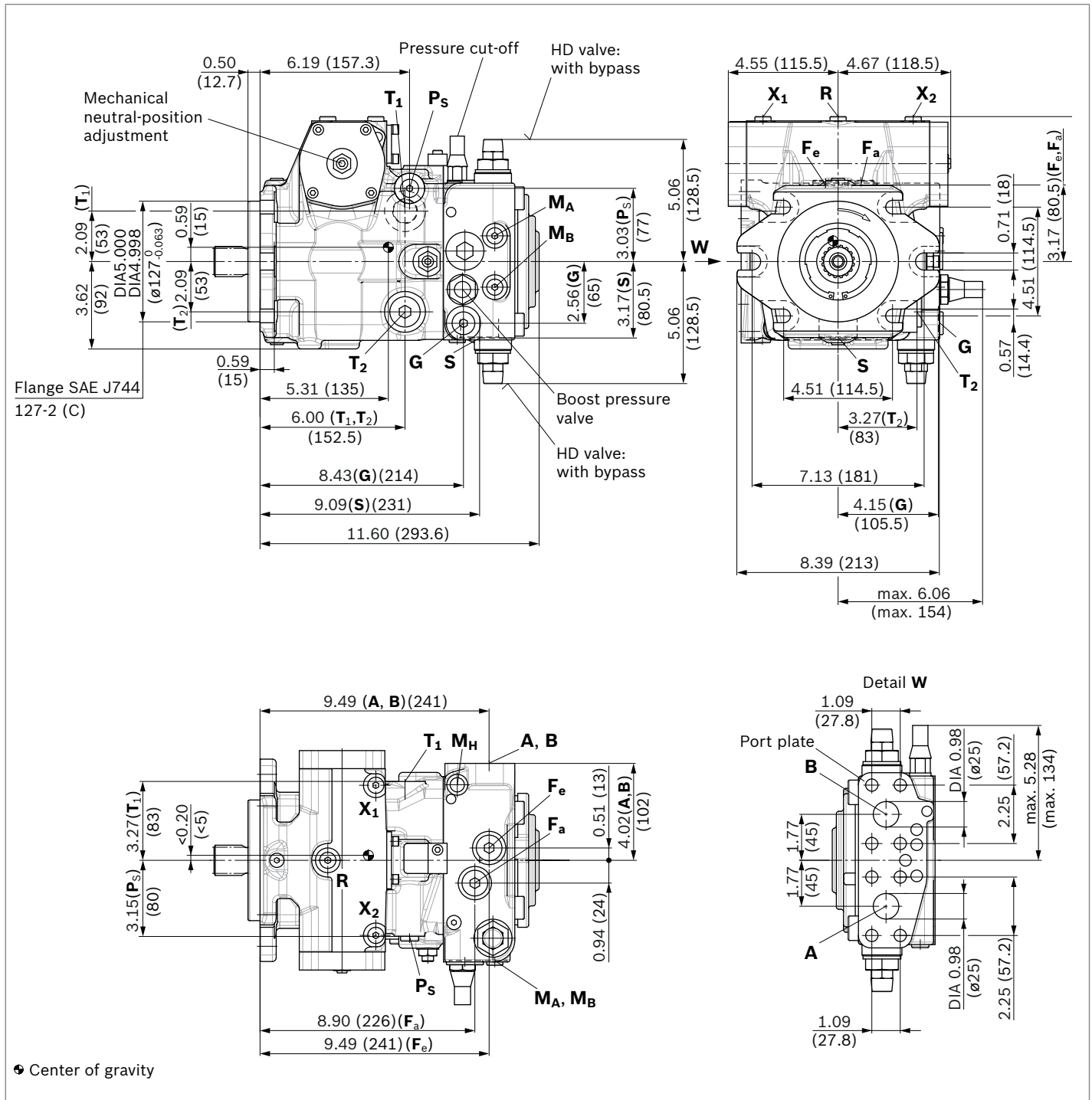

## ▼ Splined shaft ANSI B92.1a

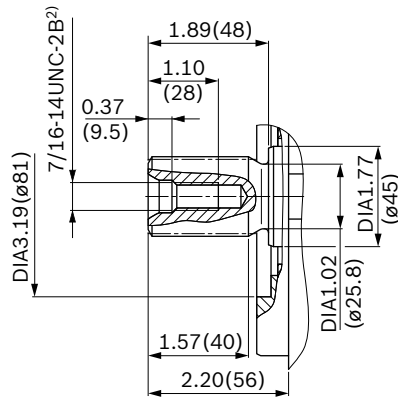
S – 1 1/4 in 14T 12/24DP<sup>1)</sup>

## ▼ Splined shaft ANSI B92.1a

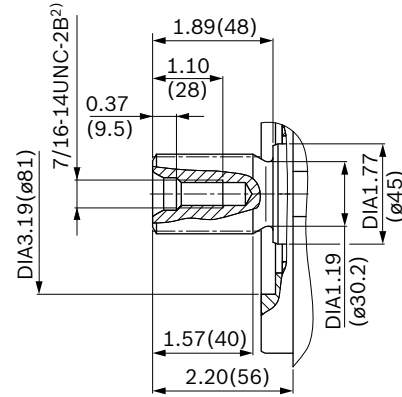
T – 1 3/8 in 21T 16/32DP<sup>1)</sup>

Ports	Standard	Size	$p_{max}$ [psi (bar)] <sup>3)</sup>	State <sup>9)</sup>
<b>A, B</b>	Working port Fastening thread	SAEJ518 <sup>4)</sup> ASME B1.1	1 in 7/16 in -14 UNC-2B; 0.67 (17) deep	6500 (450) O
<b>S</b>	Suction port	ISO 11926 <sup>7)</sup>	1 5/8 in -12 UN-2B; 0.79 (20) deep	75 (5) O <sup>5)</sup>
<b>T<sub>1</sub></b>	Drain port	ISO 11926 <sup>7)</sup>	1 1/16 in -12 UN-2B; 0.79 (20) deep	45 (3) O <sup>6)</sup>
<b>T<sub>2</sub></b>	Drain port	ISO 11926 <sup>7)</sup>	1 1/16 in -12 UN-2B; 0.79 (20) deep	45 (3) X <sup>6)</sup>
<b>R</b>	Air bleed port	ISO 11926 <sup>7)</sup>	7/16 in -20 UNF-2B; 0.47 (12) deep	45 (3) X
<b>X<sub>1</sub>, X<sub>2</sub></b>	Control pressure port (upstream of orifice)	ISO 11926 <sup>7)</sup>	7/16 in -20 UNF-2B; 0.47 (12) deep	580 (40) X
<b>X<sub>1</sub>, X<sub>2</sub></b>	Control pressure port (upstream of orifice, DG only)	ISO 11926 <sup>7)</sup>	7/16 in -20 UNF-2B; 0.47 (12) deep	580 (40) O
<b>X<sub>3</sub>, X<sub>4</sub></b> <sup>8)</sup>	Stroking chamber pressure port	ISO 11926 <sup>7)</sup>	7/16 in -20 UNF-2B; 0.47 (12) deep	580 (40) X
<b>G</b>	Boost pressure port inlet	ISO 11926 <sup>7)</sup>	3/4 in -16 UNF-2B; 0.59 (15) deep	580 (40) X
<b>P<sub>s</sub></b>	Pilot pressure port	ISO 11926 <sup>7)</sup>	9/16 in -18 UNF-2B; 0.51 (13) deep	580 (40) X
<b>M<sub>A</sub>, M<sub>B</sub></b>	Measuring port pressure A, B	ISO 11926 <sup>7)</sup>	7/16 in -20 UNF-2B; 0.47 (12) deep	6500 (450) X
<b>M<sub>H</sub></b>	Measuring port, high pressure	ISO 11926 <sup>7)</sup>	7/16 in -20 UNF-2B; 0.47 (12) deep	6500 (450) X
<b>F<sub>a</sub></b>	Boost pressure port inlet	ISO 11926 <sup>7)</sup>	1 1/16 in -12 UN-2B; 0.79 (20) deep	580 (40) X
<b>F<sub>a1</sub></b>	Boost pressure port inlet (attachment filter)	DIN 3852 <sup>7)</sup>	M22 x 1.5; 0.55 (14) deep	580 (40) X
<b>F<sub>e</sub></b>	Boost pressure port outlet	DIN 3852 <sup>7)</sup>	M22 x 1.5; 0.55 (14) deep	580 (40) X
<b>F<sub>s</sub></b>	Line from filter to suction port (cold start)	DIN 3852 <sup>7)</sup>	M22 x 1.5; 0.55 (14) deep	580 (40) X
<b>Y<sub>1</sub>, Y<sub>2</sub></b>	Pilot pressure port (pilot signal HD only)	ISO 11926 <sup>7)</sup>	9/16 in -18 UNF-2B; 0.51 (13) deep	580 (40) O
<b>Z</b>	Pilot pressure port (inch signal DA..8 only)	DIN 3852 <sup>7)</sup>	M10 x 1; 0.31 (8) deep	580 (40) X

- 1) Involute spline according to ANSI B92.1a, 30° pressure angle, flat root, side fit, tolerance class 5
- 2) Thread according to ASME B1.1
- 3) Depending on the application, momentary pressure peaks can occur. Keep this in mind when selecting measuring devices and fittings.
- 4) Only dimensions according to SAE J518, metric fastening thread is a deviation from the standard.

- 5) Plugged for external boost pressure supply.
- 6) Depending on installation position, **T<sub>1</sub>** or **T<sub>2</sub>** must be connected (see also installation instructions on page 65).
- 7) The countersink can be deeper than as specified in the standard.
- 8) Optional, see page 55
- 9) O = Must be connected (plugged when delivered)  
X = Plugged (in normal operation)

▼ **HD** – Proportional control, hydraulic, pilot-pressure related

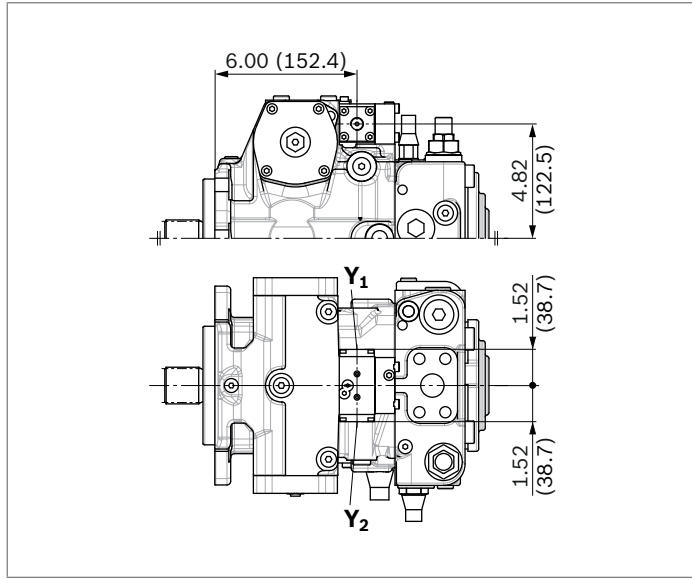

▼ **HW** – Proportional control, hydraulic, mechanical servo

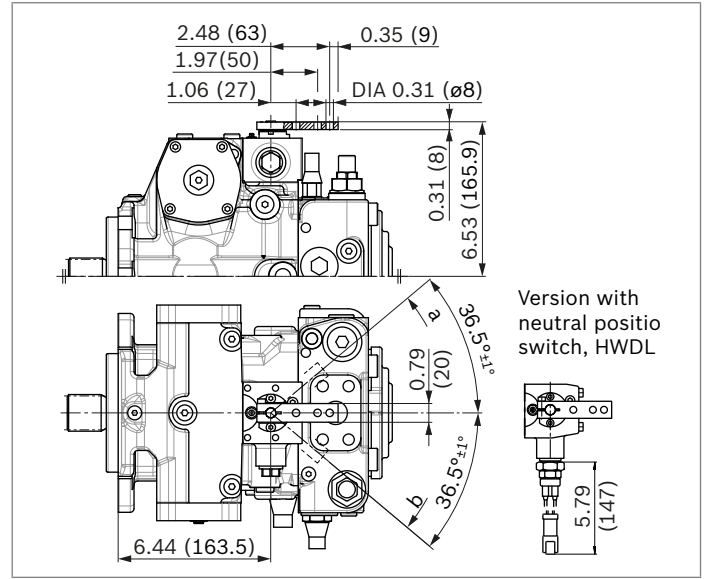

▼ **EP** – Proportional control, electric

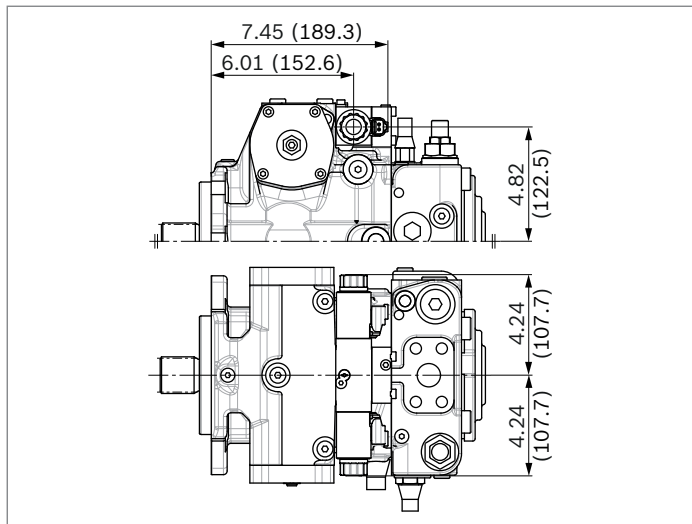

▼ **EZ** – Two-point control, electric

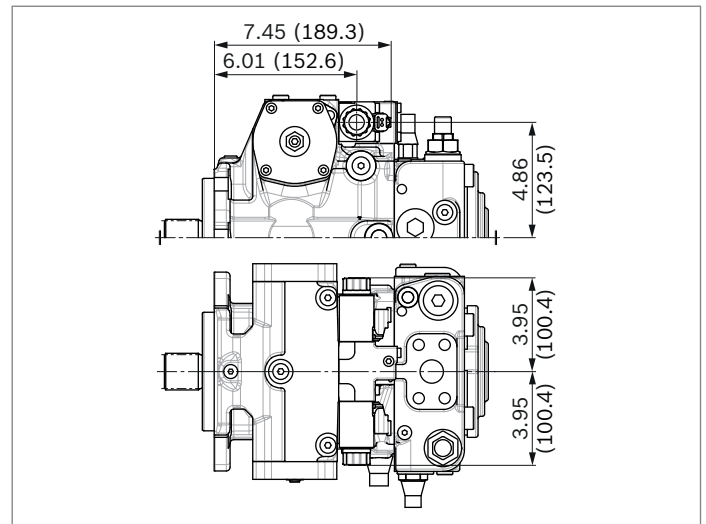

▼ **DG** – Hydraulic control, direct operated

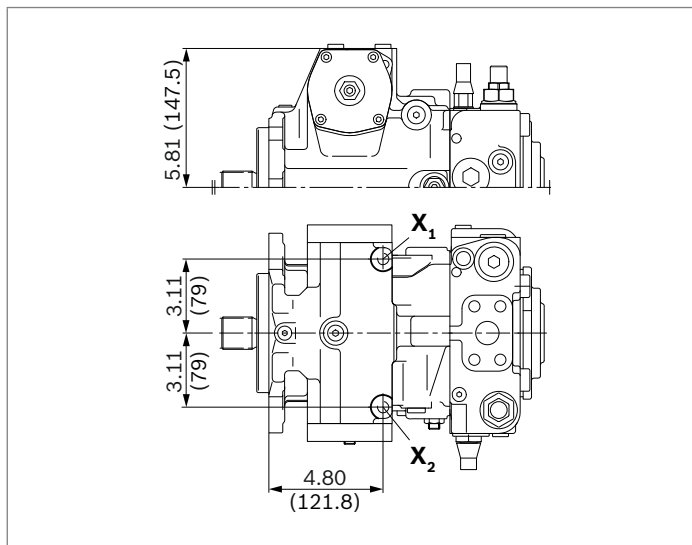

**DA control valve**

▼ **DA..2** – Fixed setting

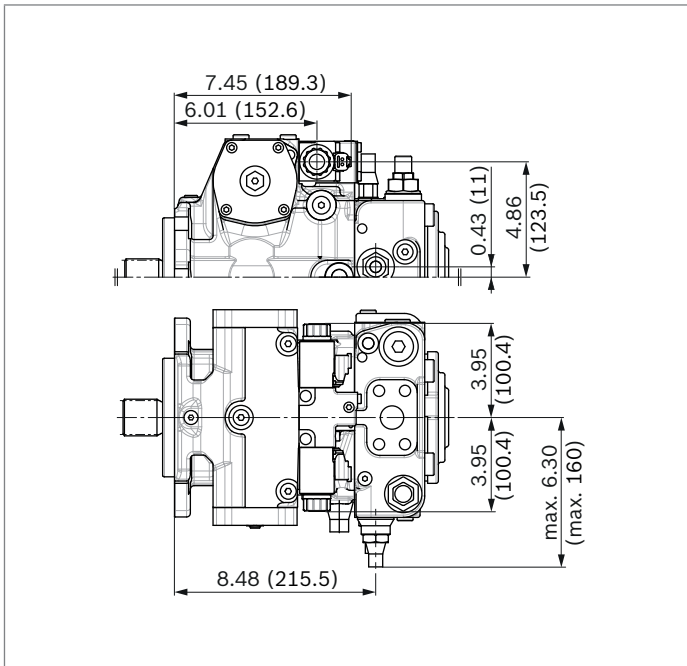

▼ **DA..3** – Mechanically adjustable with position lever

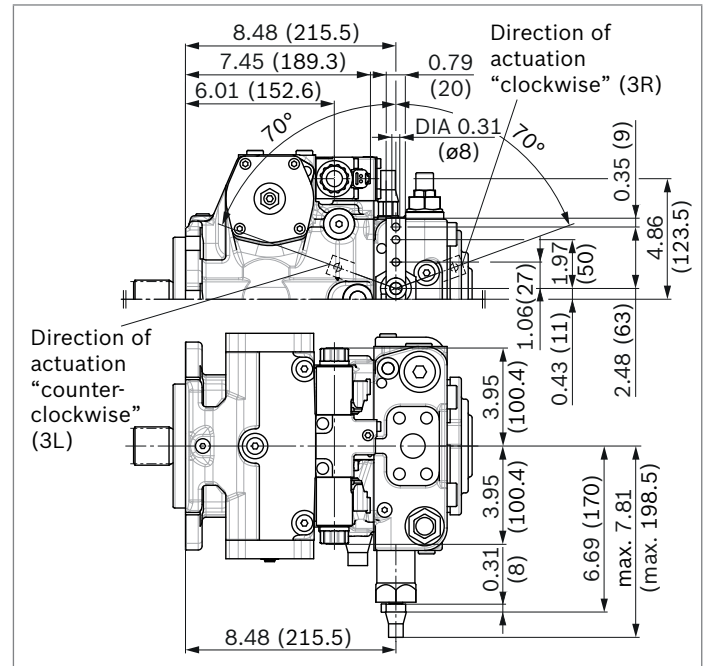

▼ **DA..8** – Fixed setting and inch valve mounted

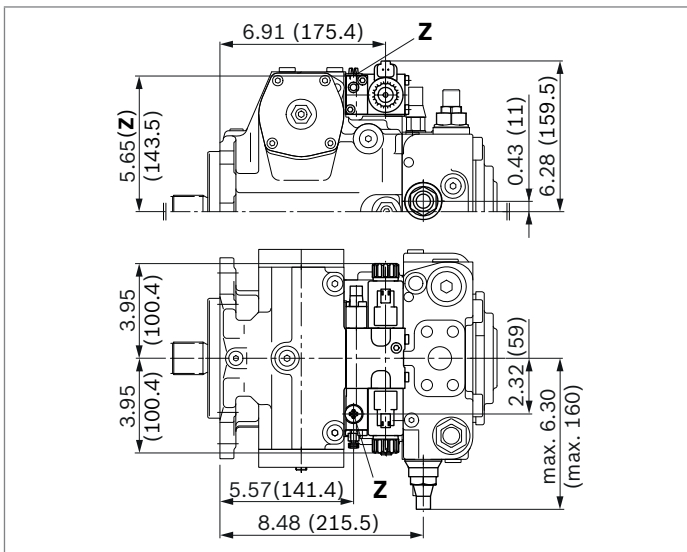

**Dimensions, size 90**

**NV – Version without control module**

Standard: SAE working port **A** and **B** top and bottom, suction port **S** bottom (52)

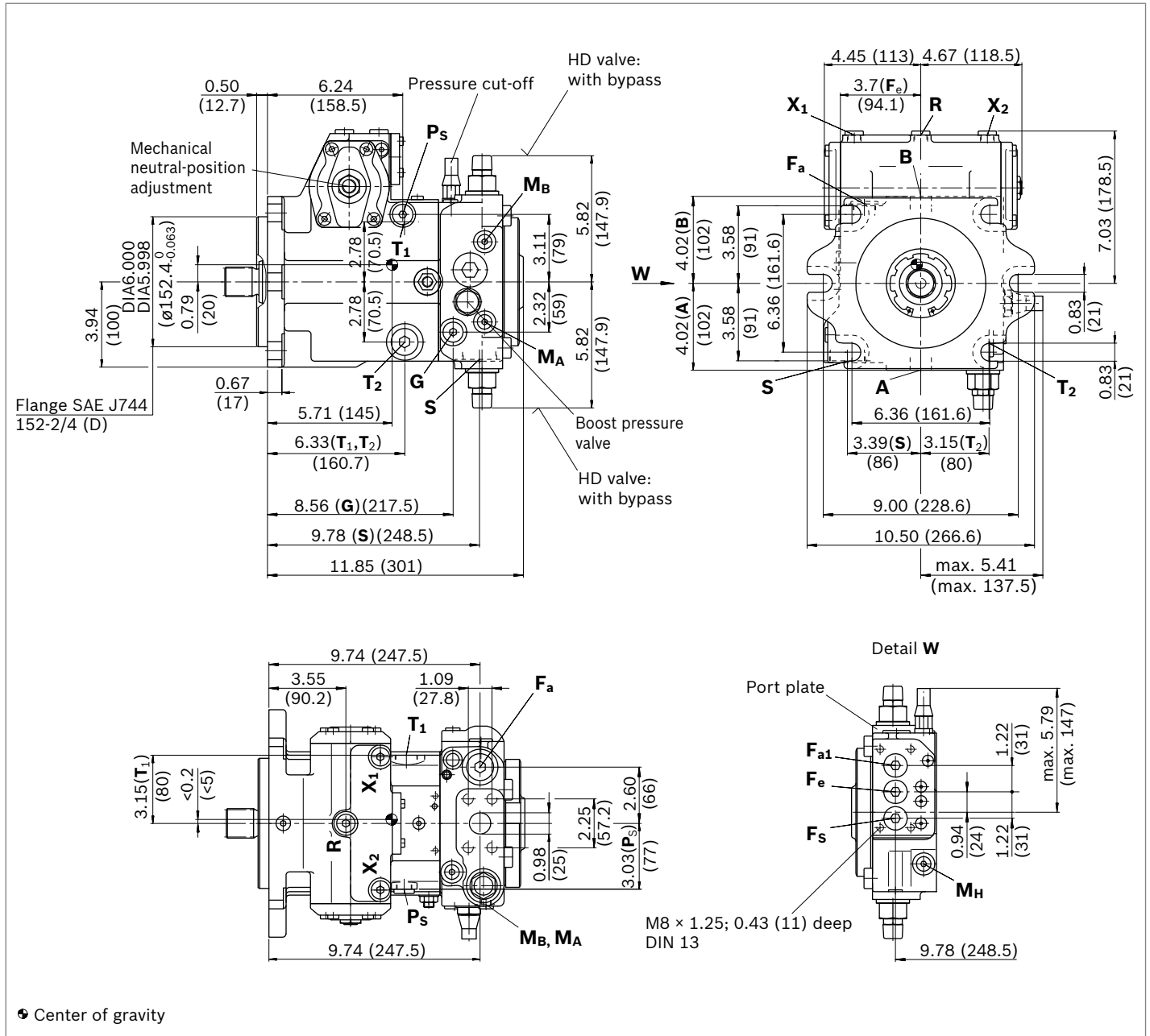



▼ Splined shaft ANSI B92.1a

**S – 1 3/4 in 13T 8/16DP<sup>1)</sup>**

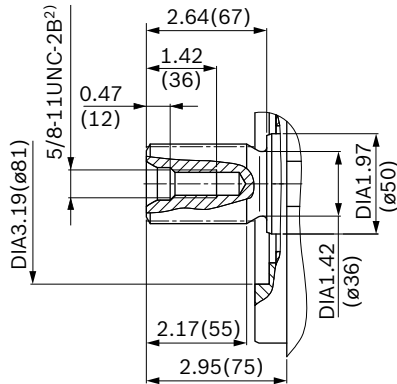

▼ Splined shaft ANSI B92.1a

**U – 1 1/4 in 14T 12/24DP<sup>1)</sup>**

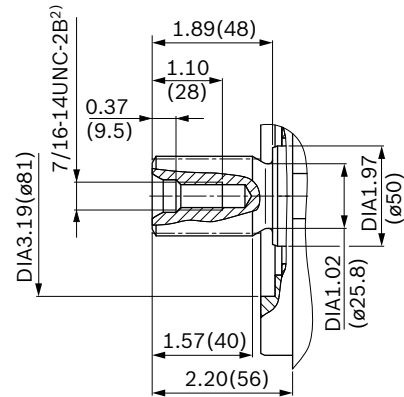

Ports	Standard	Size	$p_{max}$ [psi (bar)] <sup>3)</sup>	State <sup>9)</sup>
<b>A, B</b>	Working port Fastening thread	SAEJ518 <sup>4)</sup> ASME B1.1	1 in 7/16 in -14 UNC-2B; 0.67 (17) deep	6500 (450) O
<b>S</b>	Suction port	ISO 11926 <sup>7)</sup>	1 5/8 in -12 UN-2B; 0.79 (20) deep	75 (5) O <sup>5)</sup>
<b>T<sub>1</sub></b>	Drain port	ISO 11926 <sup>7)</sup>	1 1/16 in -12 UN-2B; 0.79 (20) deep	45 (3) O <sup>6)</sup>
<b>T<sub>2</sub></b>	Drain port	ISO 11926 <sup>7)</sup>	1 1/16 in -12 UN-2B; 0.79 (20) deep	45 (3) X <sup>6)</sup>
<b>R</b>	Air bleed port	ISO 11926 <sup>7)</sup>	9/16 in -18 UNF-2B; 0.51 (13) deep	45 (3) X
<b>X<sub>1</sub>, X<sub>2</sub></b>	Control pressure port (upstream of orifice)	ISO 11926 <sup>7)</sup>	9/16 in -18 UNF-2B; 0.51 (13) deep	580 (40) X
<b>X<sub>1</sub>, X<sub>2</sub></b>	Control pressure port (upstream of orifice, DG only)	ISO 11926 <sup>7)</sup>	9/16 in -18 UNF-2B; 0.51 (13) deep	580 (40) O
<b>X<sub>3</sub>, X<sub>4</sub><sup>8)</sup></b>	Stroking chamber pressure port	ISO 11926 <sup>7)</sup>	7/16 in -20 UNF-2B; 0.47 (12) deep	580 (40) X
<b>G</b>	Boost pressure port inlet	ISO 11926 <sup>7)</sup>	3/4 in -16 UNF-2B; 0.59 (15) deep	580 (40) X
<b>P<sub>s</sub></b>	Pilot pressure port	ISO 11926 <sup>7)</sup>	9/16 in -18 UNF-2B; 0.51 (13) deep	580 (40) X
<b>M<sub>A</sub>, M<sub>B</sub></b>	Measuring port pressure A, B	ISO 11926 <sup>7)</sup>	7/16 in -20 UNF-2B; 0.47 (12) deep	6500 (450) X
<b>M<sub>H</sub></b>	Measuring port, high pressure	ISO 11926 <sup>7)</sup>	7/16 in -20 UNF-2B; 0.47 (12) deep	6500 (450) X
<b>F<sub>a</sub></b>	Boost pressure port inlet	ISO 11926 <sup>7)</sup>	1 1/16 in -12 UN-2B; 0.79 (20) deep	580 (40) X
<b>F<sub>a1</sub></b>	Boost pressure port inlet (attachment filter)	DIN 3852 <sup>7)</sup>	M22 x 1.5; 0.55 (14) deep	580 (40) X
<b>F<sub>e</sub></b>	Boost pressure port outlet	DIN 3852 <sup>7)</sup>	M22 x 1.5; 0.55 (14) deep	580 (40) X
<b>F<sub>s</sub></b>	Line from filter to suction port (cold start)	DIN 3852 <sup>7)</sup>	M22 x 1.5; 0.55 (14) deep	580 (40) X
<b>Y<sub>1</sub>, Y<sub>2</sub></b>	Pilot pressure port (pilot signal HD only)	ISO 11926 <sup>7)</sup>	9/16 in -18 UNF-2B; 0.51 (13) deep	580 (40) O
<b>Z</b>	Pilot pressure port (inch signal DA..8 only)	DIN 3852 <sup>7)</sup>	M10 x 1; 0.31 (8) deep	580 (40) X

1) Involute spline according to ANSI B92.1a, 30° pressure angle, flat root, side fit, tolerance class 5  
 2) Thread according to ASME B1.1  
 3) Depending on the application, momentary pressure peaks can occur. Keep this in mind when selecting measuring devices and fittings.  
 4) Only dimensions according to SAE J518, metric fastening thread is a deviation from the standard.

5) Plugged for external boost pressure supply.  
 6) Depending on installation position, **T<sub>1</sub>** or **T<sub>2</sub>** must be connected (see also installation instructions on page 65).  
 7) The countersink can be deeper than as specified in the standard.  
 8) Optional, see page 55  
 9) O = Must be connected (plugged when delivered)  
 X = Plugged (in normal operation)



**DA control valve**

▼ **DA..2** – Fixed setting

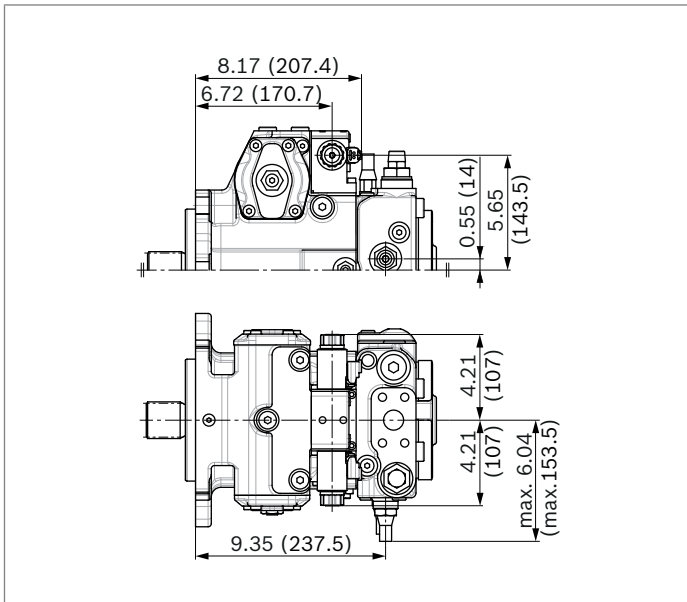

▼ **DA..3** – Mechanically adjustable with position lever

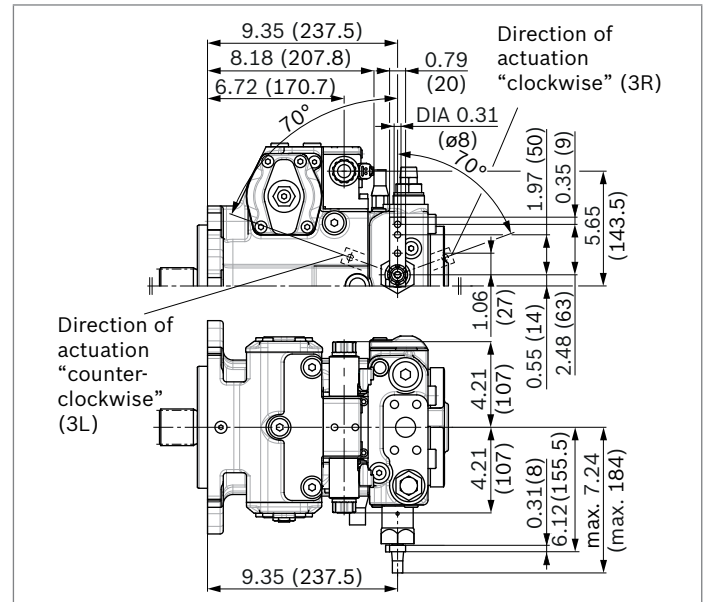

▼ **DA..8** – Fixed setting and inch valve mounted

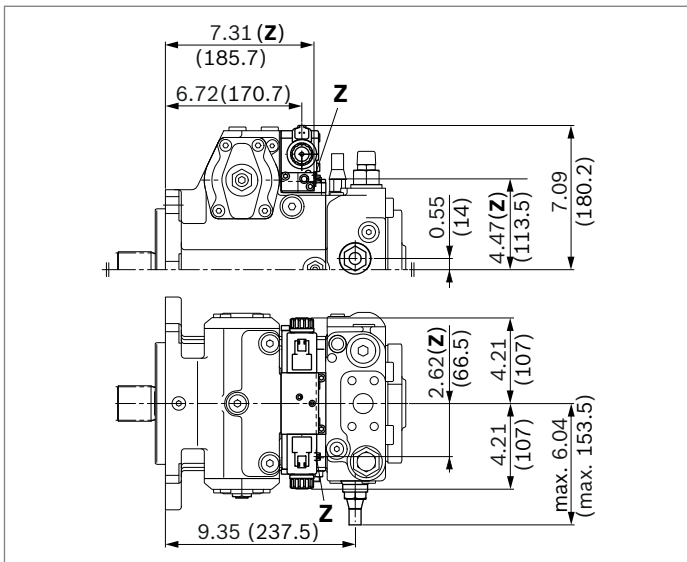

## Dimensions, size 125

### NV – Version without control module

Standard: SAE working port **A** and **B** top and bottom, suction port **S** bottom (52)

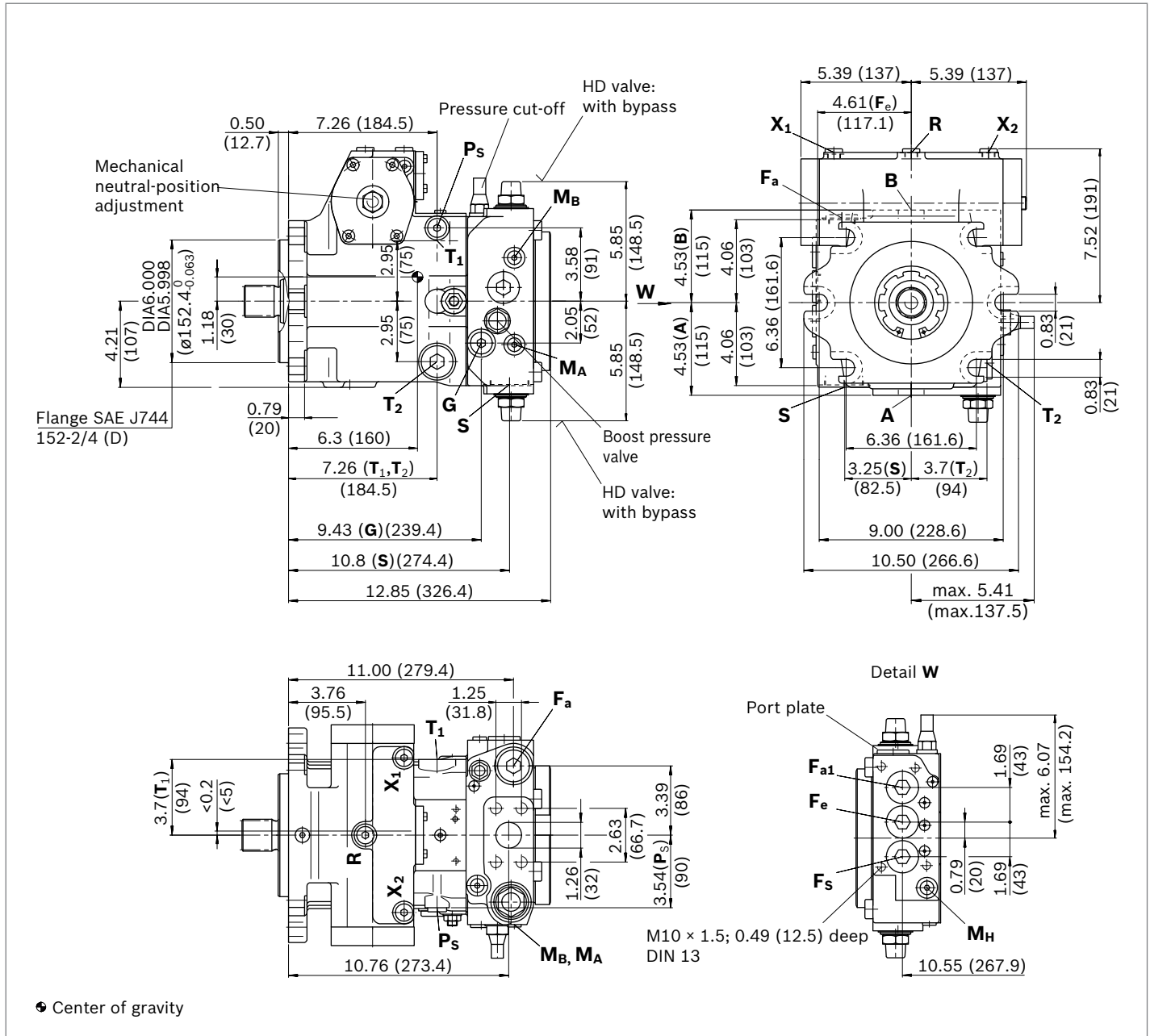

### Notice

Option: SAE working port **A** and **B** top and bottom, suction port **S** top (53). Port plate 52 rotated through 180°, installation drawing on request

## ▼ Splined shaft ANSI B92.1a

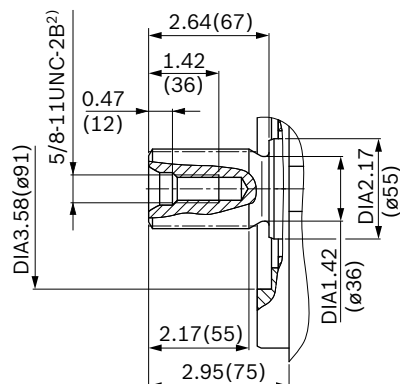
**S – 1 3/4 in 13T 8/16DP<sup>1)</sup>**

## ▼ Splined shaft ANSI B92.1a

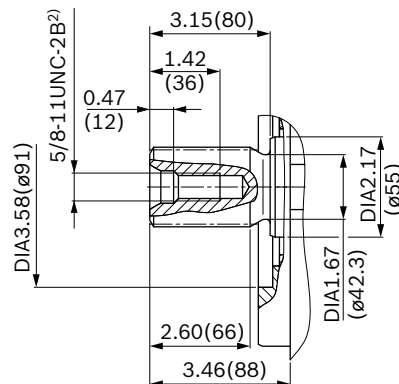
**T – 2 in 15T 8/16DP<sup>1)</sup>**

Ports	Standard	Size	$p_{max}$ [psi (bar)] <sup>3)</sup>	State <sup>9)</sup>
<b>A, B</b>	Working port Fastening thread	SAEJ518 <sup>4)</sup> ASME B1.1	1 1/4 in 1/2 in -13 UNC-2B; 0.75 (19) deep	6500 (450) O
<b>S</b>	Suction port	ISO 11926 <sup>7)</sup>	1 7/8 in -12 UN-2B; 0.79 (20) deep	75 (5) O <sup>5)</sup>
<b>T<sub>1</sub></b>	Drain port	ISO 11926 <sup>7)</sup>	1 5/16 in -12 UN-2B; 0.79 (20) deep	45 (3) O <sup>6)</sup>
<b>T<sub>2</sub></b>	Drain port	ISO 11926 <sup>7)</sup>	1 5/16 in -12 UN-2B; 0.79 (20) deep	45 (3) X <sup>6)</sup>
<b>R</b>	Air bleed port	ISO 11926 <sup>7)</sup>	9/16 in -18 UNF-2B; 0.51 (13) deep	45 (3) X
<b>X<sub>1</sub>, X<sub>2</sub></b>	Control pressure port (upstream of orifice)	ISO 11926 <sup>7)</sup>	9/16 in -18 UNF-2B; 0.51 (13) deep	580 (40) X
<b>X<sub>1</sub>, X<sub>2</sub></b>	Control pressure port (upstream of orifice, DG only)	ISO 11926 <sup>7)</sup>	9/16 in -18 UNF-2B; 0.51 (13) deep	580 (40) O
<b>X<sub>3</sub>, X<sub>4</sub><sup>8)</sup></b>	Stroking chamber pressure port	ISO 11926 <sup>7)</sup>	7/16 in -20 UNF-2B; 0.47 (12) deep	580 (40) X
<b>G</b>	Boost pressure port inlet	ISO 11926 <sup>7)</sup>	7/8 in -14 UNF-2B; 0.67 (17) deep	580 (40) X
<b>P<sub>S</sub></b>	Pilot pressure port	ISO 11926 <sup>7)</sup>	9/16 in -18 UNF-2B; 0.51 (13) deep	580 (40) X
<b>M<sub>A</sub>, M<sub>B</sub></b>	Measuring port pressure A, B	ISO 11926 <sup>7)</sup>	7/16 in -20 UNF-2B; 0.47 (12) deep	6500 (450) X
<b>M<sub>H</sub></b>	Measuring port, high pressure	ISO 11926 <sup>7)</sup>	7/16 in -20 UNF-2B; 0.47 (12) deep	6500 (450) X
<b>F<sub>a</sub></b>	Boost pressure port inlet	ISO 11926 <sup>7)</sup>	1 5/16 in -12 UN-2B; 0.79 (20) deep	580 (40) X
<b>F<sub>a1</sub></b>	Boost pressure port inlet (attachment filter)	DIN 3852 <sup>7)</sup>	M33 x 1.5; 0.71 (18) deep	580 (40) X
<b>F<sub>e</sub></b>	Boost pressure port outlet	DIN 3852 <sup>7)</sup>	M33 x 1.5; 0.71 (18) deep	580 (40) X
<b>F<sub>S</sub></b>	Line from filter to suction port (cold start)	DIN 3852 <sup>7)</sup>	M33 x 1.5; 0.71 (18) deep	580 (40) X
<b>Y<sub>1</sub>, Y<sub>2</sub></b>	Pilot pressure port (pilot signal HD only)	ISO 11926 <sup>7)</sup>	9/16 in -18 UNF-2B; 0.51 (13) deep	580 (40) O
<b>Z</b>	Pilot pressure port (inch signal DA..8 only)	DIN 3852 <sup>7)</sup>	M10 x 1; 0.31 (8) deep	580 (40) X

- 1) Involute spline according to ANSI B92.1a, 30° pressure angle, flat root, side fit, tolerance class 5
- 2) Thread according to ASME B1.1
- 3) Depending on the application, momentary pressure peaks can occur. Keep this in mind when selecting measuring devices and fittings.
- 4) Only dimensions according to SAE J518, metric fastening thread is a deviation from the standard.

- 5) Plugged for external boost pressure supply.
- 6) Depending on installation position, **T<sub>1</sub>** or **T<sub>2</sub>** must be connected (see also installation instructions on page 65).
- 7) The countersink can be deeper than as specified in the standard.
- 8) Optional, see page 55
- 9) O = Must be connected (plugged when delivered)  
X = Plugged (in normal operation)

▼ **HD** – Proportional control, hydraulic, pilot-pressure related

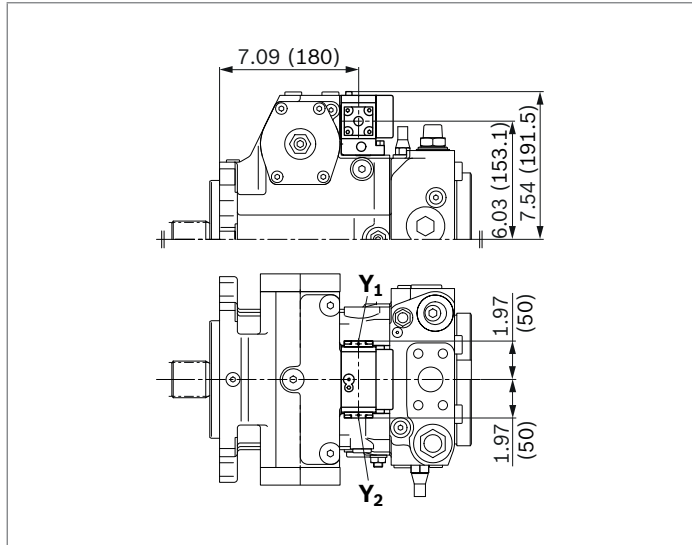

▼ **HW** – Proportional control, hydraulic, mechanical servo

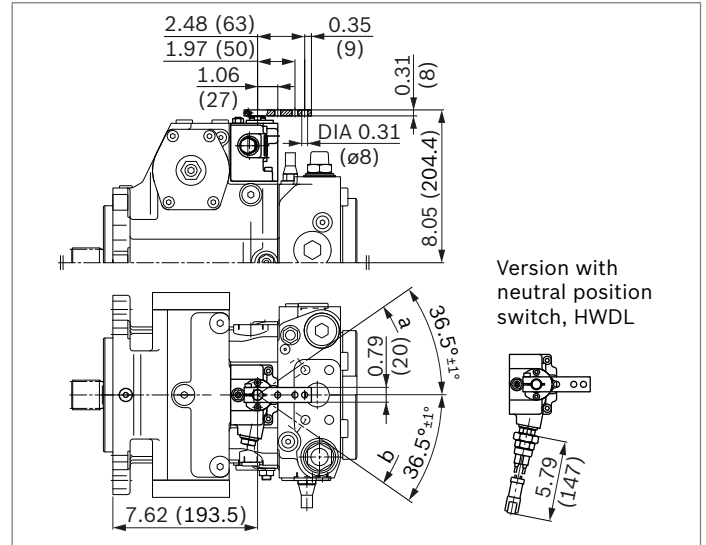

▼ **EP** – Proportional control, electric

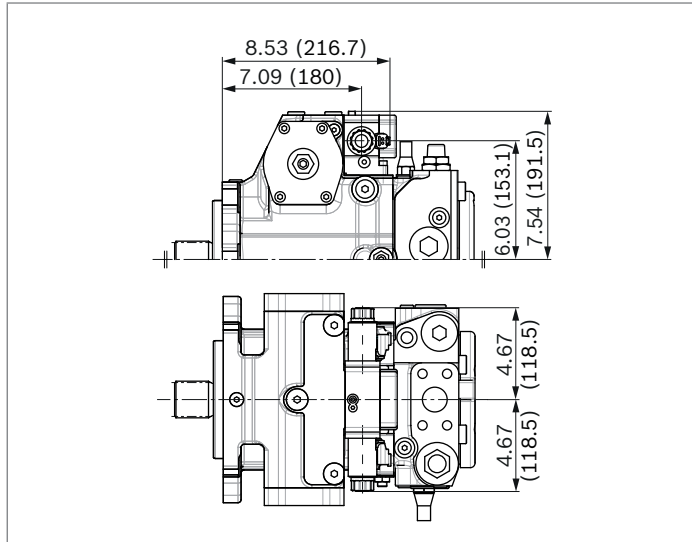

▼ **EZ** – Two-point control, electric

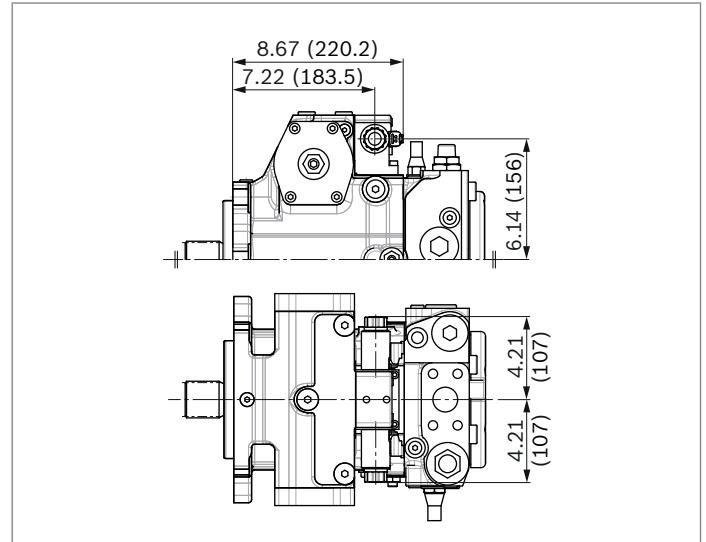

▼ **DG** – Hydraulic control, direct operated

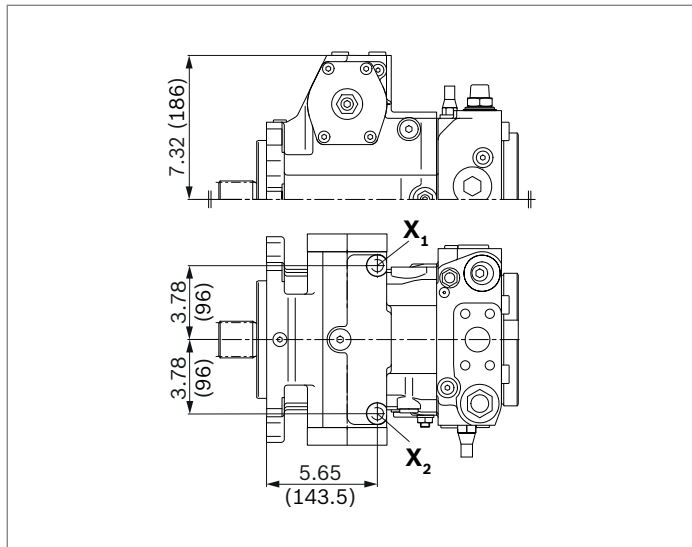

**DA control valve**

▼ **DA..2** – Fixed setting

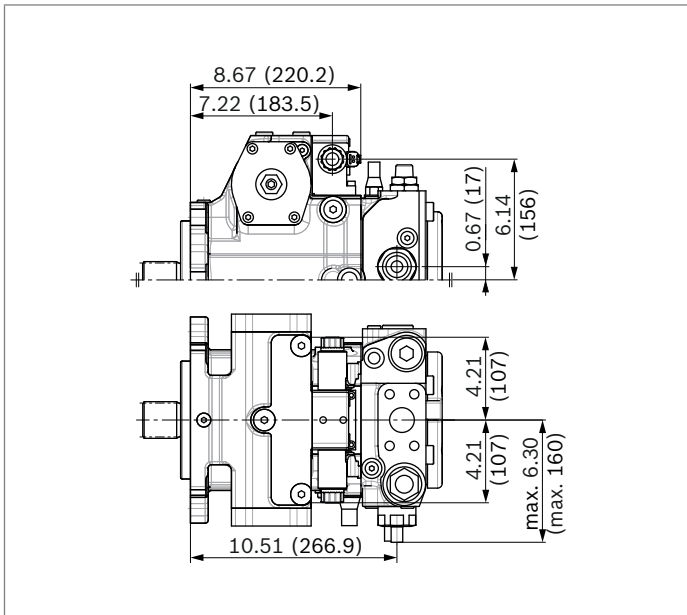

▼ **DA..3** – Mechanically adjustable with position lever

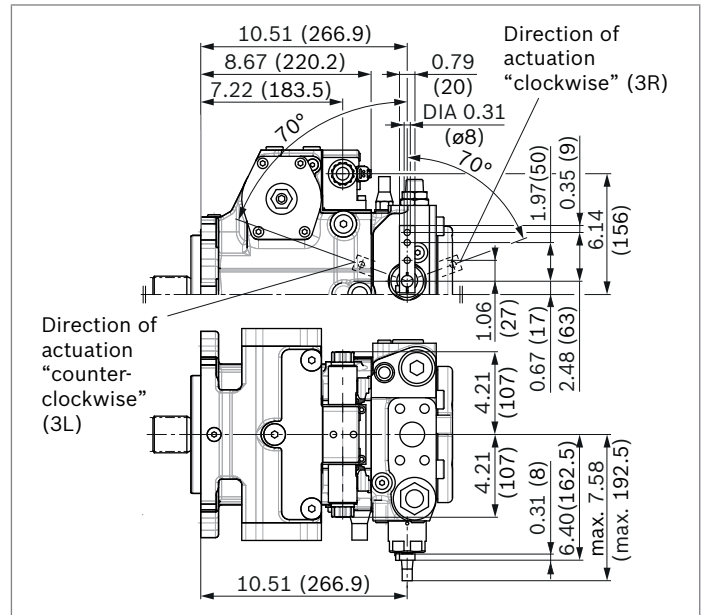

▼ **DA..8** – Fixed setting and inch valve mounted

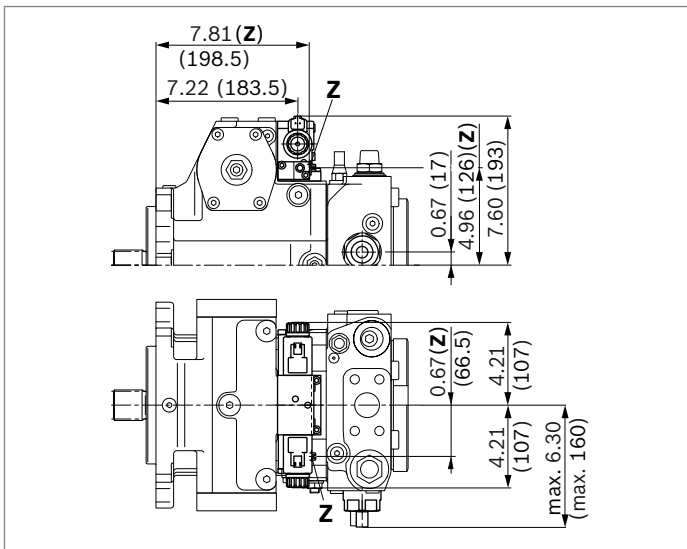

## Dimensions, through drive

Flange SAE J744	Hub for splined shaft <sup>1)</sup>	28	40	56	71	90	125	Code
Without through drive		•	•	•	•	•	•	<b>00</b>
82-2 (A)	5/8 in 9T 16/32DP	•	•	•	•	•	•	<b>01</b>

▼ **N00** – without boost pump, without through drive / **F00** – with boost pump, without through drive

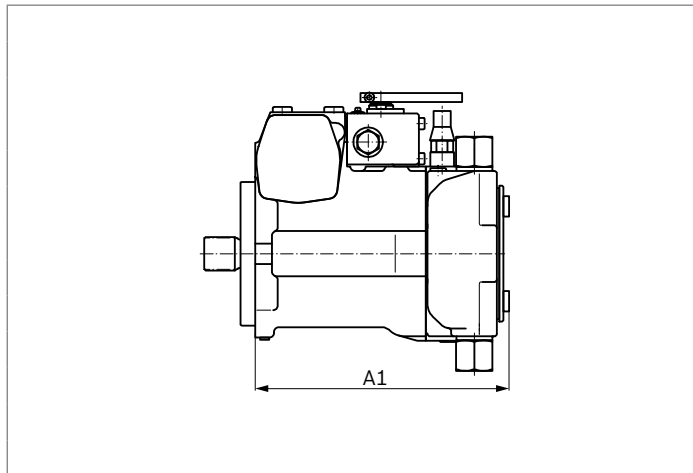

NG	A1 (N00)	A1 (F00)
<b>28</b>	8.42 (213.9)	8.80 (223.4)
<b>40</b>	8.67 (220.2)	9.28 (235.7)
<b>56</b>	9.43 (239.4)	10.09 (256.4)
<b>71</b>	10.99 (279.1)	11.56 (293.6)
<b>90</b>	11.30 (287)	11.85 (301)
<b>125</b>	12.63 (320.9)	12.85 (326.4)

▼ **F01/K01<sup>4)</sup>**

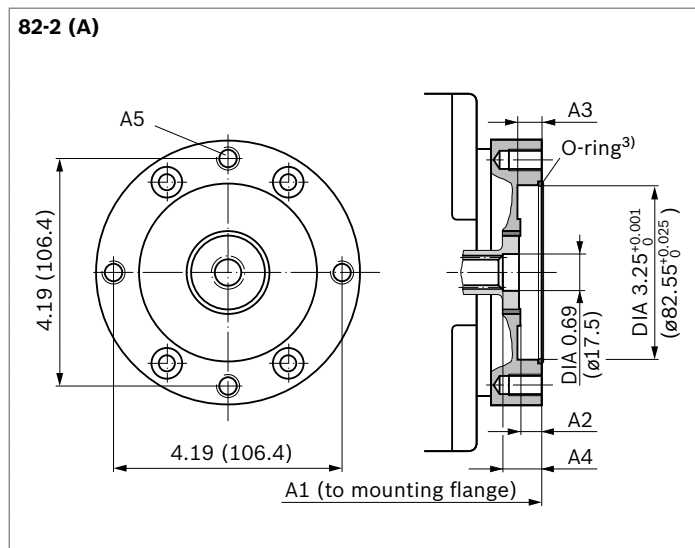

NG	A1 (F01)	A1 (K01)	A2	A3	A4
<b>28</b>	8.97 (227.9)	8.97 (227.9)	0.30 (7.5)	0.30 (7.5)	0.57 (14.5)
<b>40</b>	9.44 (239.7)	9.22 (234.2)	0.35 (9)	0.35 (9)	0.71 (18)
<b>56</b>	10.29 (261.4)	10.04 (254.9)	0.39 (10)	0.39 (10)	0.71 (18)
<b>71</b>	11.72 (297.6)	11.72 (297.6)	0.35 (9)	0.39 (10)	0.67 (17)
<b>90</b>	11.97 (304)	11.97 (304)	0.35 (9)	0.32 (8)	–
<b>125</b>	13.03 (330.9)	13.03 (330.9)	0.41 (10.5)	0.35 (9)	–
NG	A5 <sup>2)</sup>				
<b>28 to 125</b>	3/8 in -16 UNC; 0.59 (15) deep				

1) Involute spline according to ANSI B92.1a, 30° pressure angle, flat root, side fit, tolerance class 5

2) Thread according to ASME B1.1

3) O-ring included in the scope of delivery

4) The illustration shows the 2-hole version. Please state in plain text whether the 2-hole horizontal or the 2-hole vertical version is used.



Flange SAE J744	Hub for splined shaft <sup>1)</sup>	28	40	56	71	90	125	Code
101-2 (B)	7/8 in 13T 16/32DP	•	•	•	•	•	•	<b>02</b>
	1 in 15T 16/32DP	•	•	•	•	•	•	<b>04</b>

▼ **F02/K02; F04/K04<sup>4)</sup>**

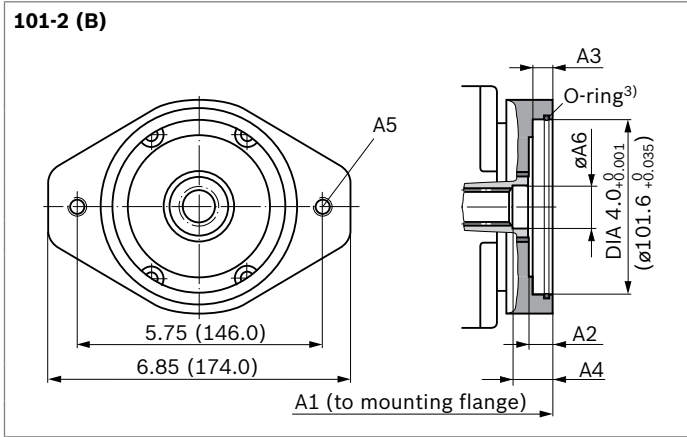

NG	A1	A2	A3	A4 (02)	A4 (04)	A5 <sup>2)</sup>
<b>28</b>	9.07 (230.4)	0.38 (9.7)	0.38 (9.7)	0.64 (16.2)	0.54 (13.7)	1/2 in -13 UNC; 0.75 (19) deep
<b>40</b>	9.48 (240.7)	0.43 (11)	0.43 <sup>5)</sup> (11) <sup>5)</sup>	0.67 (17)	0.63 (16)	1/2 in -13 UNC; 0.75 (19) deep
<b>56</b>	10.33 (262.4)	0.47 (12)	0.43 (11)	0.77 (19.5)	0.73 (18.5)	1/2 in -13 UNC; 0.75 (19) deep
<b>A6</b>						
<b>F02/K02</b>	DIA 0.94 (ø24)					
<b>F04/K04</b>	DIA 1.06 (ø27)					

▼ **F02/K02; F04/K04<sup>4)</sup>**

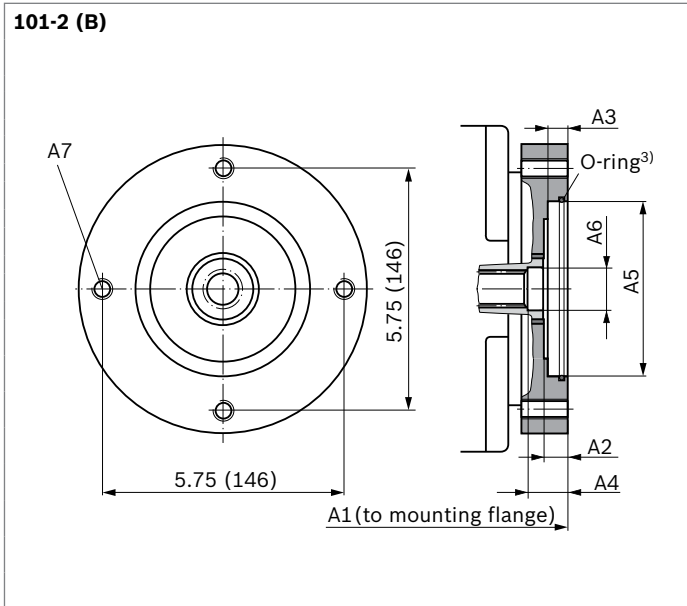

NG	A1	A2	A3	A4 (02)	A4 (04)	A5	(K)	(F)
<b>71</b>	11.83 (300.6)	0.51 (13)	0.39 (9.8)	0.67 (17)	0.61 (15.5)	DIA 4 (ø101.6)	+0.001 0	+0.001 0
<b>90</b>	12.01 (305)	0.35 (9)	0.43 (11)	0.67 (17)	0.59 (15)	DIA 4 (ø101.6)	+0.001 0	+0.001 0
<b>125</b>	13.03 (330.9)	0.39 (10)	0.43 (11)	0.67 (17)	0.65 (16.5)	DIA 4 (ø101.6)	+0.001 0	+0.001 0
<b>NG</b>		<b>A7<sup>2)</sup></b>						
<b>71, 90</b>	1/2 in -13 UNC; 0.83 (21) deep							
<b>125</b>	1/2 in -13 UNC; 0.71 (18) deep							
<b>NG</b>		<b>A6</b>						
<b>F02/K02</b>	DIA 0.94 (ø24)							
<b>F04/K04</b>	DIA 1.06 (ø27)							

1) Involute spline according to ANSI B92.1a, 30° pressure angle, flat root, side fit, tolerance class 5  
2) Thread according to ASME B1.1  
3) O-ring included in the scope of delivery

4) The illustration shows the 2-hole version. Please state in plain text whether the 2-hole horizontal or the 2-hole vertical version is used.  
5) For F04/K04 9.7 mm

Flange SAE J744	Hub for splined shaft	28	40	56	71	90	125	Code
127-2 (C)	1 1/4 in 14T 12/24DP <sup>1)</sup>	-	-	●	●	●	●	<b>07</b>
152-2/4 (D)	1 3/4 in 13T 8/16DP <sup>1)</sup>	-	-	-	-	-	●	<b>69</b>

▼ **F07/K07<sup>4)</sup>**

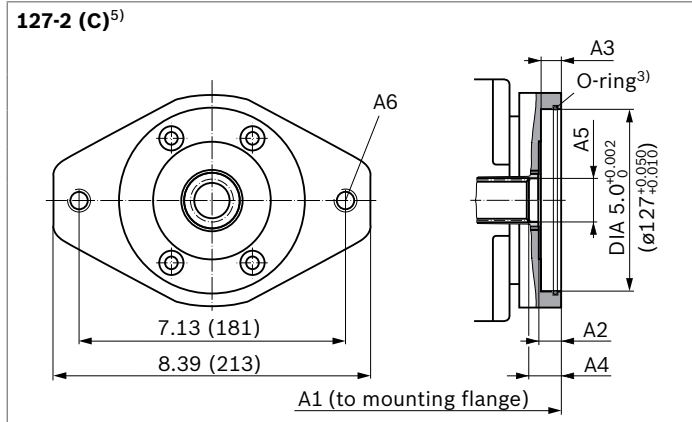

NG	A1	A2	A3	A4	A5	A6 <sup>2)</sup>
<b>56</b>	10.49 (266.4)	0.59 (15)	0.55 (14)	0.69 (17.5)	DIA 1.29 (ø32.7)	5/8 in -11 UNC; 0.79 (20) deep
<b>71</b>	11.95 (303.6)	0.59 (15)	0.53 (13.5)	0.79 (20)	DIA 1.32 (ø33.5)	5/8 in -11 UNC; 0.94 (24) deep

▼ **F07/K07<sup>4)</sup>**

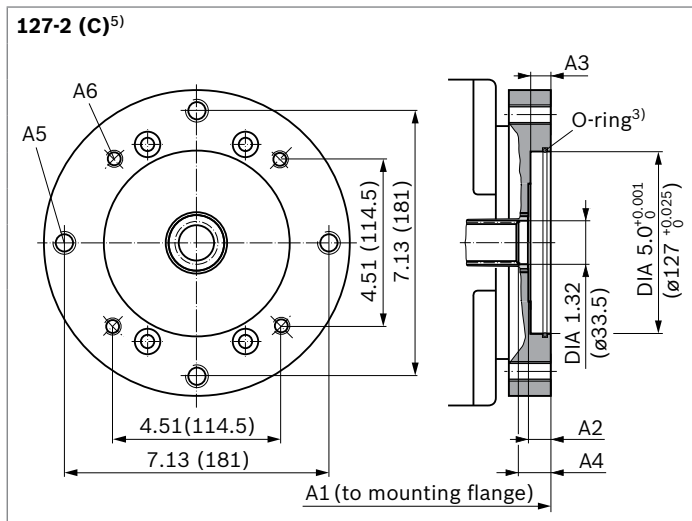

NG	A1	A2	A3	A4
<b>90</b>	12.17 (309)	0.51 (13)	0.55 (14)	0.81 (20.5)
<b>125</b>	13.22 (335.9)	0.59 (15)	0.61 (15.5)	0.89 (22.5)

NG	A5 <sup>2)</sup>	A6 <sup>2)</sup>
<b>90, 125</b>	5/8 in -11 UNC; 0.91 (23) deep	1/2 in -13 UNC; 0.71 (18) deep

▼ **F69/K69<sup>6)</sup>**

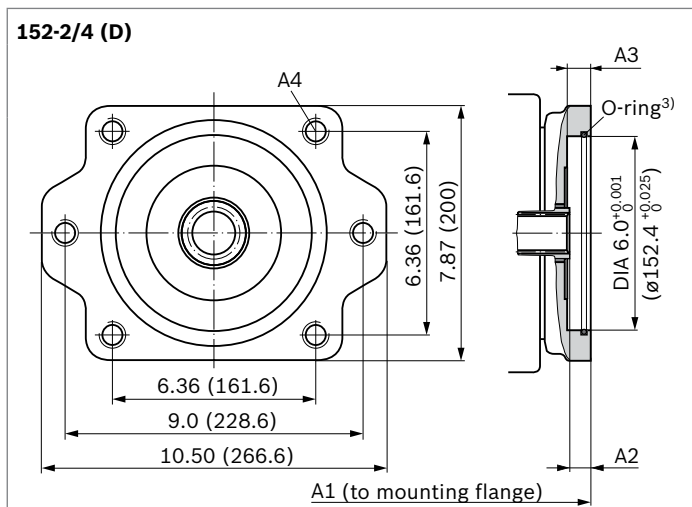

NG	A1	A2	A3	A4 <sup>2)</sup>
<b>125</b>	13.54 (343.9)	0.71 (18)	0.55 (14)	3/4 in -10 UNC; 0.79 (20) deep

- 1) Involute spline according to ANSI B92.1a, 30° pressure angle, flat root, side fit, tolerance class 5
- 2) Thread according to ASME B1.1
- 3) O-ring included in the scope of delivery
- 4) The illustration shows the 4- and the 2-hole version. Please state in plain text whether the 4-hole, the 2-hole horizontal or the 2-hole vertical version is used.
- 5) NG90 to 125 with additional 4-hole-flange (127-4)
- 6) The illustration shows the 4+2-hole version. Please state in plain text whether the 2-hole, the 4-hole or the 4+2-hole vertical version is used.

**Overview of mounting options**

Through drive <sup>1)</sup>		Mounting option – 2. pump						
Flange	Hub for splined shaft	Code	AA4VG/32 NG (shaft)	A10V(S)O/3X NG (shaft)	A10V(S)O/5X NG (shaft)	A11VO/1 NG (shaft)	A10VG NG (shaft)	External gear pump <sup>2)</sup>
82-2 (A)	5/8 in	<b>F/K01</b>	–	18 (U)	10, 18 (U)	–	–	AZPF NG4 to 22
101-2 (B)	7/8 in	<b>F/K02</b>	–	28 (S) 45 (U)	28 (S) 45 (U)	–	18 (S)	AZPN NG20 to 36 AZPG NG32 to 50
	1 in	<b>F/K04</b>	28 (S)	45 (S)	45 (S) 60, 63, 72 (U)	40 (S)	28 (S) 45 (S)	–
127-2 (C) <sup>3)</sup>	1 1/4 in	<b>F/K07</b>	40, 56, 71 (S)	71 (S) 100 (U)	60, 63, 71 (S) 85, 100 (U)	60 (S)	63 (S)	–
152-2/4 (D)	1 3/4 in	<b>F/K69</b>	90, 125 (S)	140 (S)	–	95, 130, 145 (S)	–	–

1) Availability of the individual sizes, see type code on page 3.

2) Bosch Rexroth recommends special versions of the gear pumps.  
Please contact us.

3) A10VO/5X with 4-hole flange attachable only to AA4VG  
NG90 to 125

## Combination pumps AA4VG + AA4VG

### Total length A

AA4VG 1st pump	AA4VG 2. Pump <sup>1)</sup>					
	NG28	NG40	NG56	NG71	NG90	NG125
NG28	17.87 (453.8)	–	–	–	–	–
NG40	18.27 (464.1)	18.90 (480.4)	–	–	–	–
NG56	19.13 (485.8)	19.77 (502.1)	22.58 (522.8)	–	–	–
NG71	20.63 (524.0)	21.23 (539.3)	22.05 (560.0)	23.51 (597.2)	–	–
NG90	20.80 (528.4)	21.44 (544.7)	22.26 (565.4)	23.72 (602.6)	24.02 (610.0)	–
NG125	21.82 (554.3)	22.50 (571.6)	23.32 (592.3)	24.78 (629.5)	25.39 (644.9)	26.39 (670.3)

By using combination pumps, it is possible to have independent circuits without the need for splitter gearboxes. When ordering combination pumps, the type designations of the 1st and 2nd pumps must be linked by a “+”.

Order example:

**AA4VG56EP3D1/32R-NAC02F073SP +  
 AA4VG56EP3D1/32R-NSC02F003SP**

A tandem pump, with two pumps of equal size, is permissible without additional supports, assuming that the dynamic acceleration does not exceed maximum  $10 g = 322 \text{ ft/s}^2$  ( $98.1 \text{ m/s}^2$ ).

From size 71 upward, we recommend using the 4-hole mounting flange.

For combination pumps consisting of more than two pumps, the mounting flange must be rated for the permissible moment of inertia, please consult us.

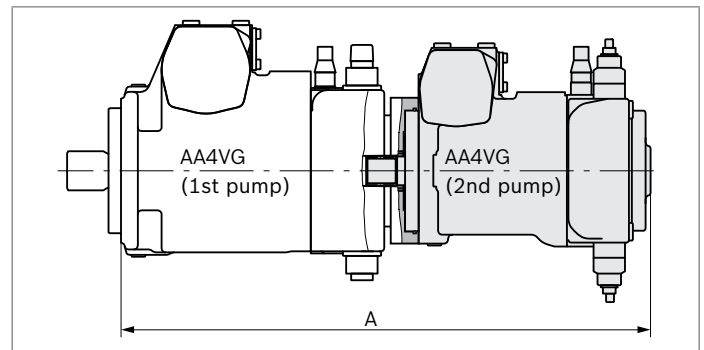

1) 2nd pump without through drive and with boost pump, F00

## High-pressure relief valves

The two high-pressure relief valves protect the hydrostatic transmission (pump and motor) from overloading. They limit the maximum pressure in the respective high-pressure line and serve simultaneously as boost valves.

High-pressure relief valves are not working valves and are only suitable for pressure peaks or high rates of pressure change.

### Setting ranges

High-pressure relief valve, direct operated (NG28 to 56)	Differential pressure setting $\Delta p_{HD}$
Valve setting range <b>3, 5</b>	6100 psi (420 bar)
$\Delta p$ 3600 to 420 psi (250 to 420 bar) (see type code)	5800 psi (400 bar)
	5200 psi (360 bar)
	4950 psi (340 bar)
	4650 psi (320 bar)
	4350 psi (300 bar)
	3900 psi (270 bar)
	3600 psi (250 bar)
Valve setting range <b>4, 6</b>	3600 psi (250 bar)
$\Delta p$ 870 to 3600 psi (100 to 250 bar) (see type code)	3350 psi (230 bar)
	2900 psi (200 bar)
	2200 psi (150 bar)
	1450 psi (100 bar)

High-pressure relief valve, pilot operated (NG71 to 125)	Differential pressure setting $\Delta p_{HD}$
Valve setting range <b>1</b>	6100 psi (420 bar)
$\Delta p$ 1450 to 6100 psi (100 to 420 bar) (see type code)	5800 psi (400 bar)
	5200 psi (360 bar)
	4950 psi (340 bar)
	4650 psi (320 bar)
	4350 psi (300 bar)
	3900 psi (270 bar)
	3600 psi (250 bar)
	3350 psi (230 bar)
	2900 psi (200 bar)
	2200 psi (150 bar)
	1450 psi (100 bar)

### Settings on high-pressure relief valve A and B

Differential pressure setting	$\Delta p_{HD} = \dots$ bar
Cracking pressure of the HD valve (at $q_{V1}$ ) ( $p_{max} = \Delta p_{HD} + p_{Sp}$ )	$p_{max} = \dots$ bar

- ▶ The valve settings are made at  $n = 1000$  rpm and at  $V_{g\ max}$  ( $q_{V1}$ ). There may be deviations in the cracking pressures with other operating parameters.
- ▶ When ordering, state differential pressure setting in plain text.

### ▼ Example

Working pressure	Boost pressure	Safety	Differential pressure
$p_{A,B}$	$p_{Sp}$		$\Delta p_{HD}$
5800 psi (400 bar)	435 psi (30 bar)	435 psi (30 bar)	<b>5800 psi (400 bar)</b>

### ▼ Setting diagram

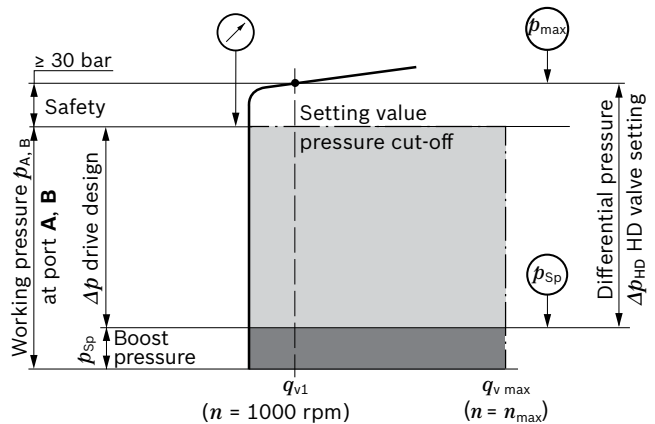

### Bypass function

A connection between the two high-pressure channels **A** and **B** can be established using the bypass valve (e.g. for machine towing).

#### ▶ Towing speed

The maximum towing speed is dependent on the gear ratio in the vehicle and must be calculated by the vehicle manufacturer. The corresponding flow of  $q_v = 7.9$  gmp (30 l/min) may not be exceeded.

#### ▶ Towing distance

The vehicle may only be towed out of the immediate danger zone.

For further information on the bypass function, see the instruction manual.

### Notice

The bypass function and the pilot-operated high pressure relief valves (size 71 to 125) are not illustrated in the circuit diagrams.

## Pressure cut-off

The pressure cut-off is a pressure control which, after reaching the set pressure, adjusts the displacement of the pump back to  $V_{g \min}$ .

This valve prevents the operation of the high-pressure relief valves when accelerating or decelerating.

The high-pressure relief valves protect against the pressure peaks which occur during fast swiveling of the swashplate and limit the maximum pressure in the system.

The setting range of the pressure cut-off may be anywhere within the entire working pressure range. However, it must be set 435 psi (30 bar) lower than the setting value of the high-pressure relief valves (see setting diagram, page 53).

Please state the setting value of the pressure cut-off in plain text when ordering.

### ▼ Circuit diagram with pressure cut-off

Example: Two-point electric control, EZ1D/EZ2D

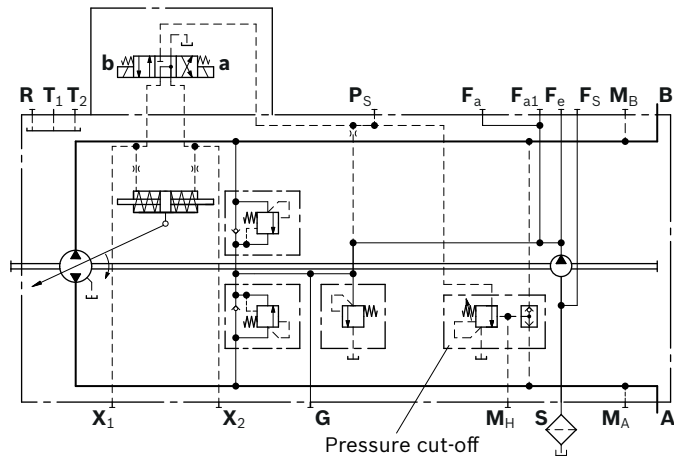

## Mechanical stroke limiter

The mechanical stroke limiter is an auxiliary function allowing the maximum displacement of the pump to be steplessly reduced, regardless of the control module used.

By means of two threaded pins, the stroke of the stroking piston and thus the maximum swivel angle of the pump can be limited.

### Dimensions

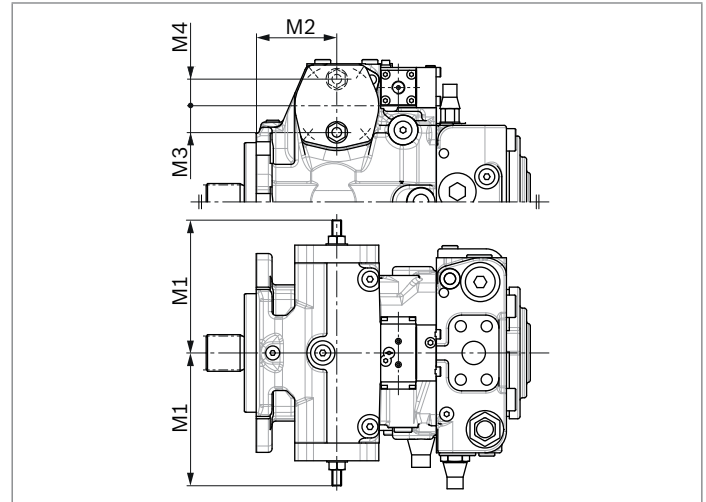

NG	M1 max.	M2	M3	M4
28	4.35 (110.6)	1.58 (40.1)	0.94 (24)	-
40	4.35 (110.6)	1.50 (38.1)	0.94 (24)	-
56	5.14 (130.5)	1.73 (44)	1.00 (25.5)	-
71	5.33 (135.4)	3.40 (86.3)	-	1.12 (28.5)
90	5.79 (147)	3.77 (95.7)	1.24 (31.5)	-
125	6.84 (173.7)	4.11 (104.5)	-	1.40 (35.5)

### ▼ Circuit diagram<sup>1)</sup>

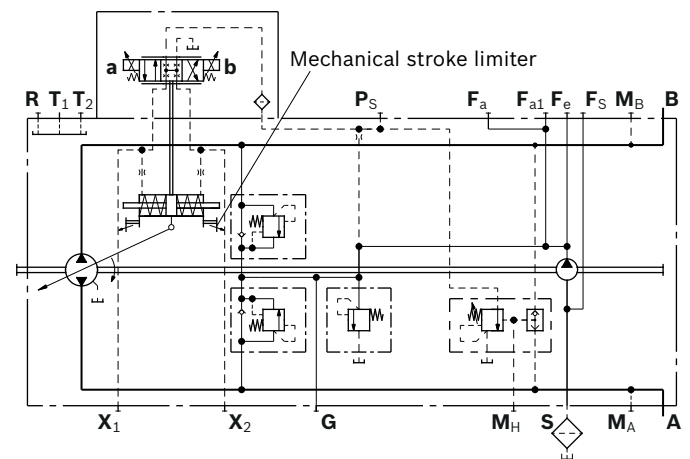

1) Size 28 without port  $F_{a1}$  and  $F_S$

### Stroking chamber pressure port X<sub>3</sub> and X<sub>4</sub>

#### Dimensions

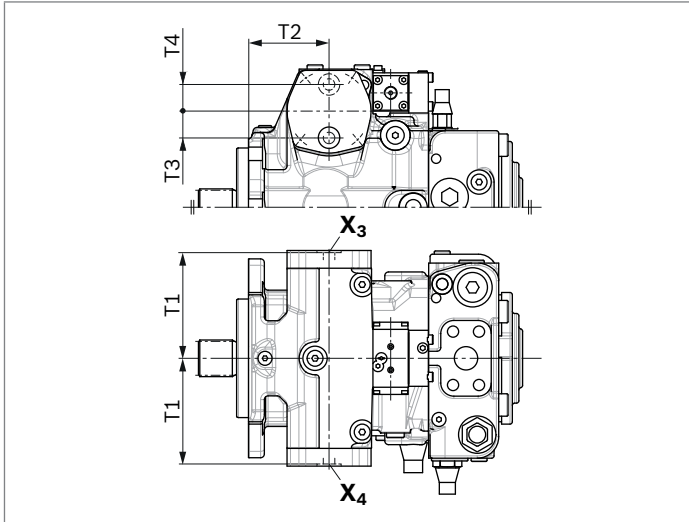

#### ▼ Circuit diagram<sup>1)</sup>

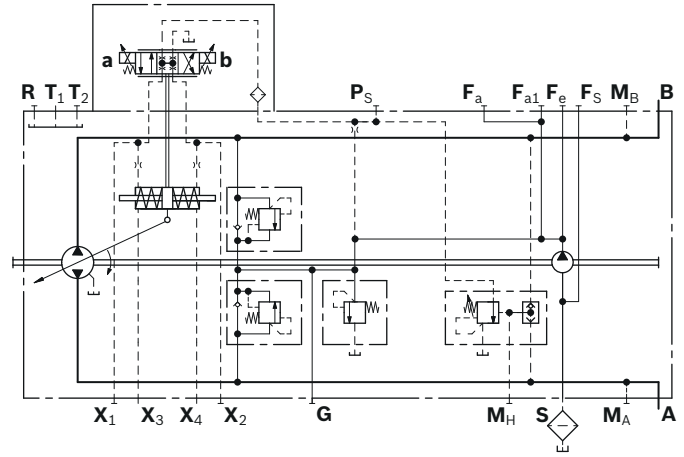

NG	T1	T2	T3	T4
<b>56</b>	4.11 (104.5)	1.73 (44)	-	0.98 (25)
<b>71</b>	4.47 (113.5)	3.40 (86.3)	1.10 (28)	-
<b>90</b>	4.39 (111.5)	3.77 (95.7)	-	1.18 (30)
<b>125</b>	5.35 (136)	4.11 (104.5)	1.34 (34)	-

Ports	Standard <sup>2)</sup>	Size	$p_{max}$ [psi (bar)] <sup>3)</sup>	State <sup>4)</sup>
X <sub>3</sub> , X <sub>4</sub>	ISO 11926	7/16in-20 UNF-2B; 0.47 (12) deep	580 (40)	X

1) Size 28 without port F<sub>a1</sub> and F<sub>s</sub>  
 2) The countersink can be deeper than as specified in the standard.

3) Depending on the application, momentary pressure peaks can occur. Keep this in mind when selecting measuring devices and fittings.  
 4) X = Plugged (in normal operation)

## Filtration in the boost pump suction line

### Version S

Filter version	Suction filter without bypass
Recommendation	With contamination indicator
Recommended flow resistance at filter element	
At $v = 140$ SUS (30 mm <sup>2</sup> /s), $n = n_{\max}$	$\Delta p \leq 1.5$ psi (0.1 bar)
At $v = 4600$ SUS (1000 mm <sup>2</sup> /s), $n = n_{\max}$	$\Delta p \leq 4.5$ psi (0.3 bar)
Pressure at suction port S	
Continuous $p_{S \min}$ ( $v \leq 140$ SUS (30 mm <sup>2</sup> /s))	$\geq 12$ psi (0.8 bar) absolute
Short-term, at a cold start ( $t < 3$ min)	$\geq 7.5$ psi (0.5 bar) absolute
Maximum pressure $p_{S \max}$	$\leq 75$ psi (5 bar) absolute

Use of version S is preferred.

The suction filter is not included in the scope of delivery.

### ▼ Circuit diagram

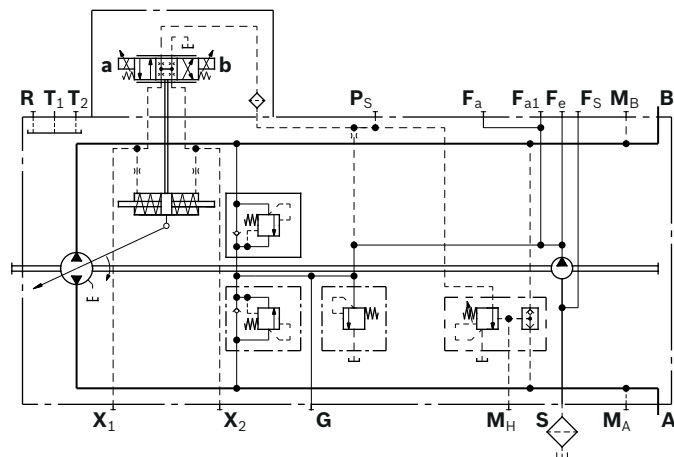

## Filtration in the boost pump pressure line

### Version D

#### Ports for external boost circuit filtration

Ports	
Boost pressure inlet	Port $F_a$
Boost pressure outlet	Port $F_e$
Filter version	Boost pressure filter without bypass
Recommendation	With contamination indicator
Filter arrangement	Separate in the pressure line (inline filter)
Permissible flow resistance at filter element <sup>1)</sup>	
At $v = 140$ SUS (30 mm <sup>2</sup> /s)	$\Delta p \leq 15$ psi (1 bar)
For cold start	$\Delta p \leq 45$ psi (3 bar)

### Notice

- Filters with a bypass **not recommended**, (exception DG, see below). Please contact us for applications with a bypass.
- On versions with DG control (with pilot pressure not from a boost circuit), a filter **with** a bypass and **with** a contamination indicator must be used.

The boost pressure filter is not included in the scope of delivery.

### ▼ Dimensions

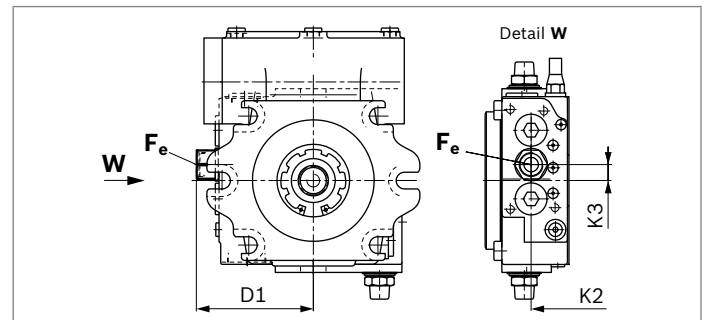

NG	D1 <sup>1)</sup>	Fe <sup>2)</sup>
28	See page 23	3/4 in-16 UNF-2B; 0.59 (15) deep
40	4.49	3/4 in-16 UNF-2B; 0.59 (15) deep (113)
56	4.57	3/4 in-16 UNF-2B; 0.59 (15) deep (116)
71	5.27	1 1/16 in-12 UN; 0.63 (16) deep (133.9)
90	5.04	1 1/16 in-12 UN; 0.63 (16) deep (128)
125	5.83	1 5/16 in-12 UN-2B; 0.63 (16) deep (148)

1) Valid for entire speed range  $n_{\min}$  to  $n_{\max}$



▼ **Circuit diagram**

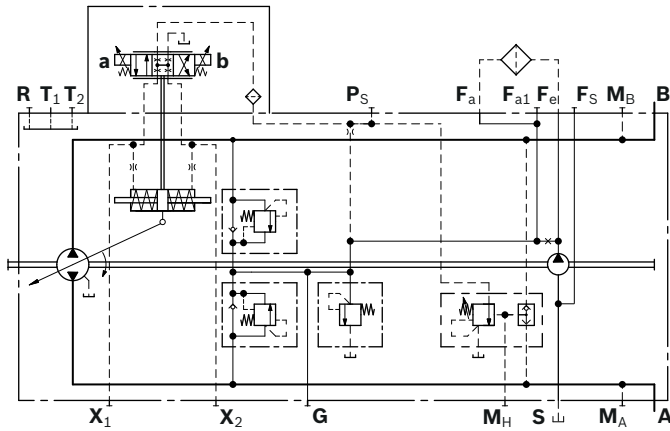

**Version K**

**Mounted cold start valve and ports for external boost circuit filtration**

Filtration as version D, but with additional cold start valve. The port plate is equipped with a cold start valve to protect the pump against damage. The valve opens at flow resistance of  $\Delta p \geq 6$  bar.

Ports	
Boost pressure inlet	Port $F_a$
Boost pressure outlet	Port $F_e$
Filter version	<b>Boost pressure filter without bypass</b>
Recommendation	With contamination indicator
Filter arrangement	Separate in the pressure line (inline filter)
Permissible flow resistance at filter element <sup>1)</sup>	
At $v = 30 \text{ mm}^2/\text{s}$	$\Delta p \leq 1 \text{ bar}$
For cold start	$\Delta p \leq 3 \text{ bar}$

The boost pressure filter is not included in the scope of delivery.

▼ **Dimensions**

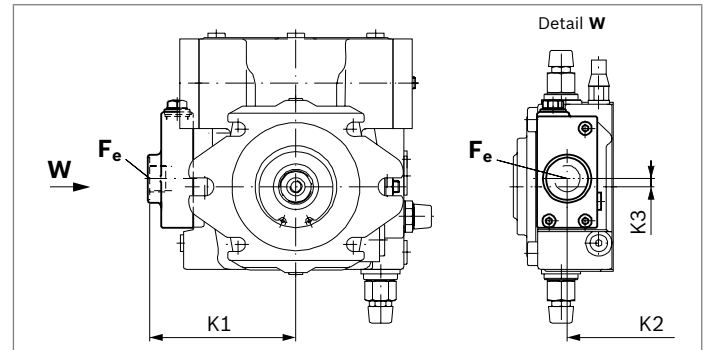

NG	K1	K2	K3	$F_e^{2)}$
<b>40</b>	4.82 (122.5)	7.82 (198.7)	0 (0)	3/4 in-16 UNF-2B; 0.59 (15) deep
<b>56</b>	4.94 (125.5)	8.48 (215.4)	0 (0)	3/4 in-16 UNF-2B; 0.59 (15) deep

▼ **Circuit diagram**

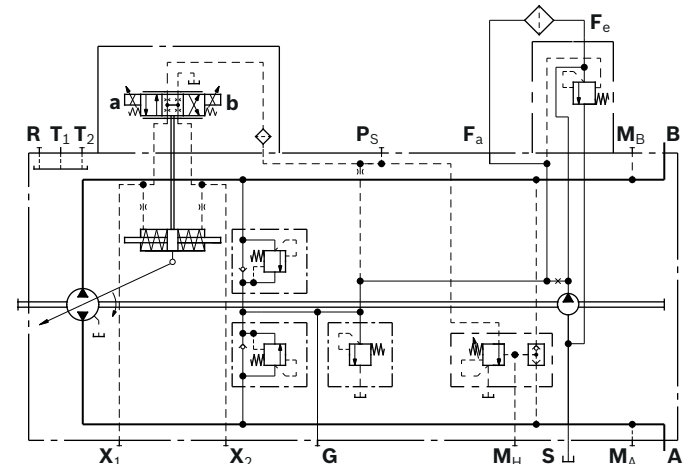

1) Valid for entire speed range  $n_{\min} - n_{\max}$   
 2) Thread according to ISO 11926;  
 The countersink may be deeper than specified in the standard.  
 3) To protect the filter element against electrostatic charge, the hydraulic fluid must have a minimum conductivity of 300 pS/m on versions with attachment filter F, P and B. Please contact us if this value cannot be observed.

**Version F<sup>1)</sup>**

**Attachment filter with cold start valve**

Filter version	Attachment filter without bypass
Recommendation	Version with contamination indicator, see P, B (differential pressure $\Delta p = 75 \text{ psi (5 bar)}$ )
Filter grade (absolute)	20 $\mu\text{m}$
Filter material	Glass fiber
Pressure rating	1450 psi (100 bar)
Filter arrangement	Mounted on pump

The attachment filter is equipped with a cold start valve and thereby protects the pump from damage. The valve opens at flow resistance of  $\Delta p \geq 87 \text{ psi (6 bar)}$ .

▼ **Filter characteristics**

Differential pressure/flow characteristics to ISO 3968 (valid for clean filter element).

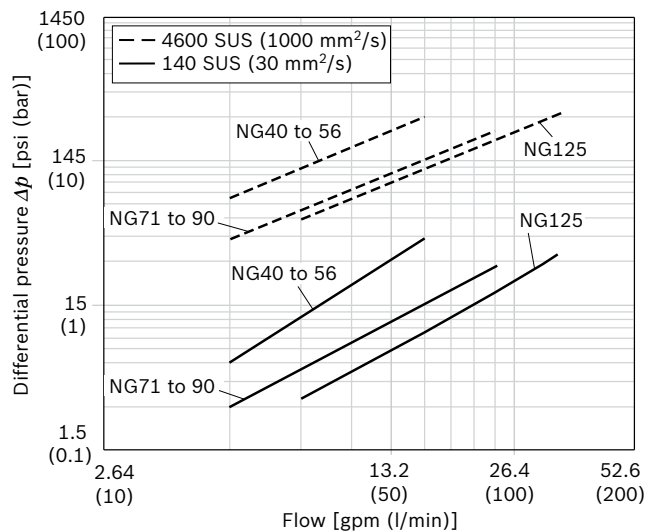

▼ **Circuit diagram**

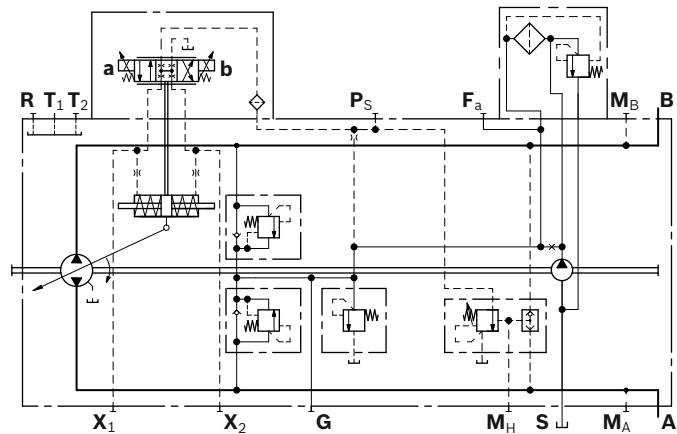

**Version P<sup>1)</sup>**

**Attachment filter with cold start valve and visual contamination indicator**

Filtration similar to version F, however with additional visual contamination indicator.

Technical data	
Display type	Green/red window
Differential pressure (switching pressure)	$\Delta p = 75 \text{ psi (5 bar)}$

▼ **Circuit diagram**

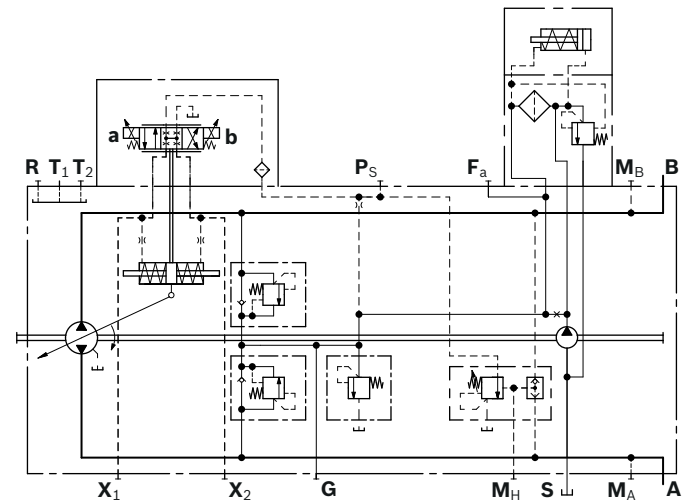

1) To protect the filter element against electrostatic charge buildup, the hydraulic fluid must have a minimum conductivity of 300 pS/m on versions with attachment filter F, P and B. Please contact us if this value cannot be observed.

**Version B<sup>1)</sup>**

**Attachment filter with cold start valve and electric contamination indicator**

Filtration similar to version F, however with additional electric contamination indicator.

**Technical data**

Display type	Electrical	
Connector version (mating connector, see page 62)	DEUTSCH DT04-2P-EP04	
Differential pressure (switching pressure)	$\Delta p = 75 \text{ psi (5 bar)}$	
Maximum switching capacity	12 V DC	24 W
	24 V DC	48 W
Type of protection IP67	DIN EN 60529	

▼ **Circuit diagram**

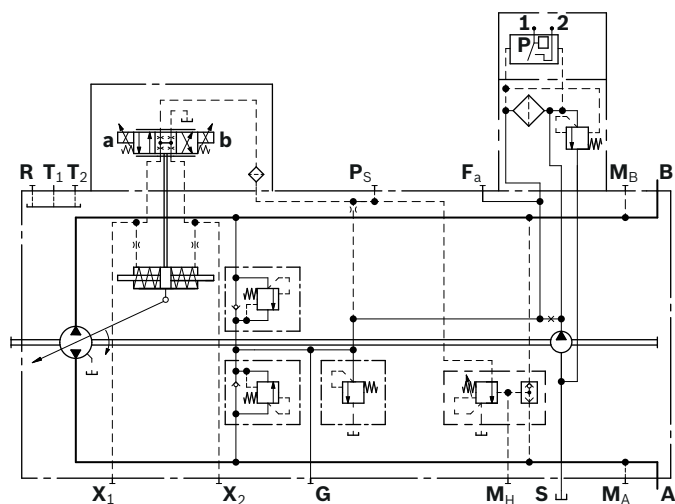

**External boost pressure supply**

**Version E**

This variation should be used in versions without integrated boost pump (**N** and **K**).

Port **S** is plugged.

The boost pressure supply comes from port **F<sub>a</sub>**.

The filter should be installed separately on port **F<sub>a</sub>** before the boost pressure supply.

To ensure the functional reliability, maintain the required cleanliness level for the boost fluid fed in at port **F<sub>a</sub>** (see page 6).

▼ **Circuit diagram**

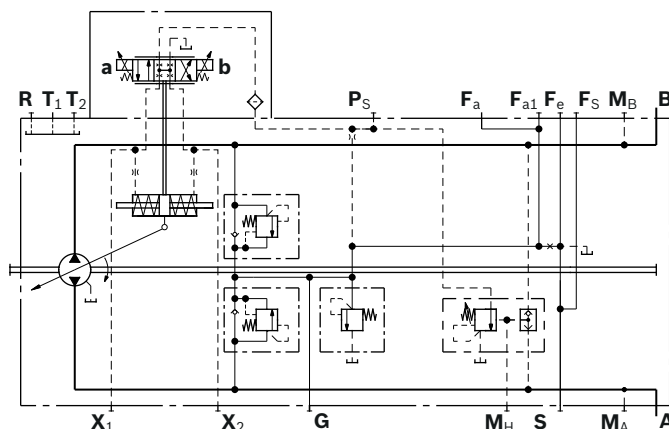

1) To protect the filter element against electrostatic charge buildup, the hydraulic fluid must have a minimum conductivity of 300 pS/m on versions with attachment filter F, P and B. Please contact us if this value cannot be observed.

### Dimensions with filter fitted

▼ **Version F**

Attachment filter with cold start valve

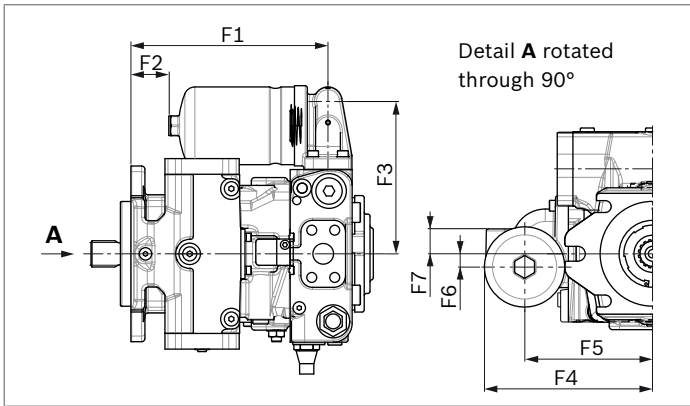

NG	F1	F2	F3	F4	F5	F6	F7	F8
<b>40</b>	7.94 (201.7)	1.88 (47.7)	6.30 (160)	6.89 (175)	5.31 (135)	0 (0)	1.65 (42)	3.09 (78.5)
<b>56</b>	8.60 (218.4)	2.54 (64.4)	6.42 (163)	7.01 (178)	5.43 (138)	0 (0)	1.65 (42)	3.09 (78.5)
<b>71</b>	9.41 (239)	1.83 (46.5)	7.28 (185)	8.01 (203.5)	6.10 (155)	0.63 (16)	1.14 (29)	2.58 (65.5)
<b>90</b>	9.78 (248.5)	2.20 (56)	7.05 (179)	7.78 (197.5)	5.87 (149)	0 (0)	1.77 (45)	3.21 (81.5)
<b>125</b>	9.29 (235.9)	2.34 (59.4)	7.91 (201)	8.64 (219.5)	6.73 (171)	0 (0)	2.09 (53)	3.52 (89.5)

▼ **Version P**

Attachment filter with cold start valve and visual contamination indicator

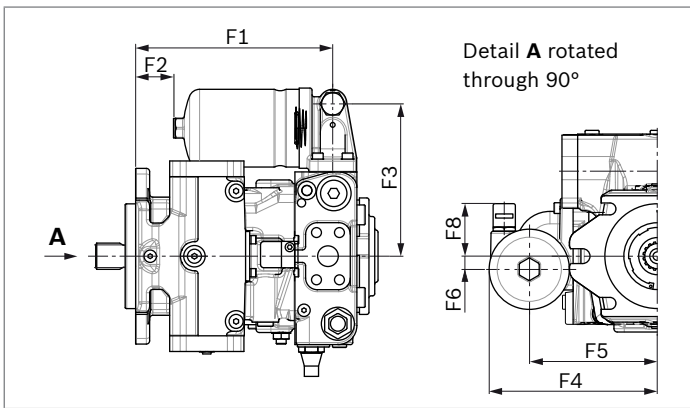

▼ **Version B**

Attachment filter with cold start valve and electric contamination indicator

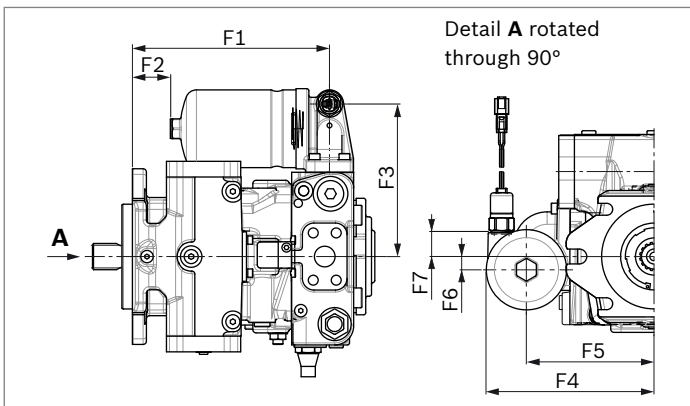

### Swivel angle sensor

The swivel angle sensor is used to detect the swivel angle of axial piston units and thus the displacement using a Hall-effect based sensor IC. The determined measurement value is converted into an analog signal.

Please contact us if the swivel angle sensor is used for control.

Characteristics	
Supply voltage $U_b$	10 to 30 V DC
Output voltage $U_a$	0.5 V $(V_{g \max})$ 2.5 V $(V_{g 0})$ 4.5 V $(V_{g \max})$
Reverse polarity protection	Short-circuit resistant
EMC resistance	Details on request
Operating temperature range	-40 °F to +239 °F (-40 °C to +115 °C)
Vibration resistance, sinusoidal vibration EN 60068-2-6	10 g / 5 to 2000 Hz
Shock resistance: continuous shock IEC 68-2-29	25 g
Salt spray resistance (DIN 50 021-SS)	96 h
Type of protection with installed mating connector	IP67 – DIN/EN 60529 IP69K – DIN 40050-9
Housing material	Plastic
Connector version	AMP Super Seal 1.5

### Output voltage

Direction of rotation	Flow direction	Working pressure	Output voltage	
			at $V_{g 0}$	at $V_{g \max}$
clockwise	A to B	$M_B$	2.5 V	4.5 V
	B to A	$M_A$	2.5 V	0.5 V
counter-clockwise	B to A	$M_A$	2.5 V	4.5 V
	A to B	$M_B$	2.5 V	0.5 V

### ▼ Circuit diagram

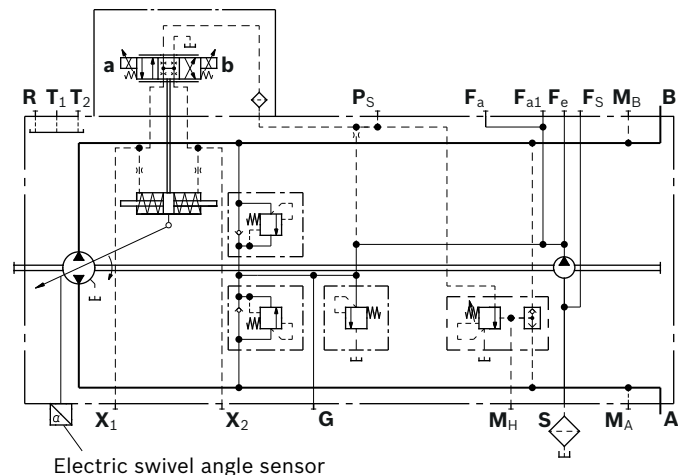

### Dimensions

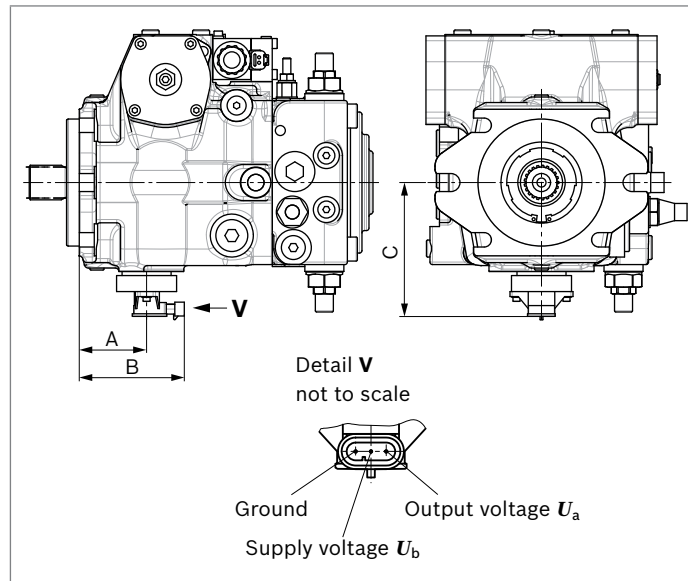

NG	A	B	C
56	2.38 (60.5)	3.84 (97.5)	5.06 (128.5)

### Mating connector AMP Superseal 1.5; 3-pin

Consisting of	AMP No.
1 socket housing, 3-pin	282087-1
3 single-wire seals, yellow	281934-2
3 socket contacts 1.8 - 3.3 mm	183025-1

The mating connector is not included in the scope of delivery. This can be supplied by Bosch Rexroth on request (material number R902602132).

### Notice

It is not possible to retrofit existing units with a swivel angle sensor.

## Connector for solenoids

### DEUTSCH DT04-2P-EP04

- ▶ **P:** Molded, 2-pin, without bidirectional suppressor diode (standard).
- ▶ **Q:** Molded, 2-pin, with bidirectional suppressor diode (only for switching solenoids on control module EZ and DA)

The following type of protection ensues with the installed mating connector:

- ▶ IP67 (DIN/EN 60529) and
- ▶ IP69K (DIN 40050-9)

The protection circuit with bidirectional suppressor diode is needed to limit overvoltages. Overvoltages are caused by switching off the current with switches, relay contacts or by disconnecting the mating connector while voltage is applied.

#### ▼ Switching symbol

**Without** bidirectional suppressor diode

**With** bidirectional suppressor diode



#### ▼ Mating connector DEUTSCH DT06-2S-EP04

Consisting of	DT designation
1 housing	DT06-2S-EP04
1 wedge	W2S
2 sockets	0462-201-16141

The mating connector is not included in the scope of delivery. This can be supplied by Bosch Rexroth on request (material number R902601804).

#### Notice

- ▶ If necessary, you can change the position of the connector by turning the solenoid.
- ▶ The procedure is defined in the instruction manual.

### Rotary inch valve

Any reduction of the pilot pressure possible, independently of the drive speed, through mechanical actuation of the position lever. Maximum angle of rotation 90°, lever position: any. The valve is arranged separately from the pump and is connected to the pump by a hydraulic control line via port **P<sub>S</sub>** (maximum line length: approx. 6.5 ft (2 m)). The rotary inch valve must be ordered separately.

NG	Material number	Direction of actuation of the position lever	Throttle cross-section DIA (Ø)
28, 40, 56, 71, 90	R902048738	Clockwise	0.18 (4.6)
	R902048739	Counter-clockwise	0.18 (4.6)

#### Notice

The rotary inch valve can be used regardless of the control module.

▼ **Circuit diagram:**  
Hydraulic control, speed-related,  
DA with separately attached rotary inch valve

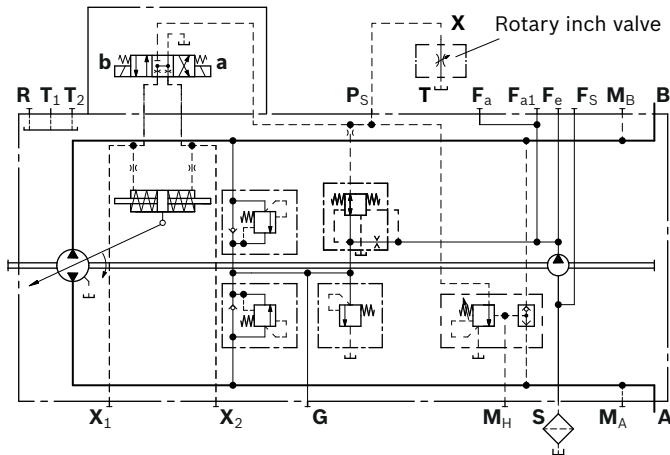

### Dimensions

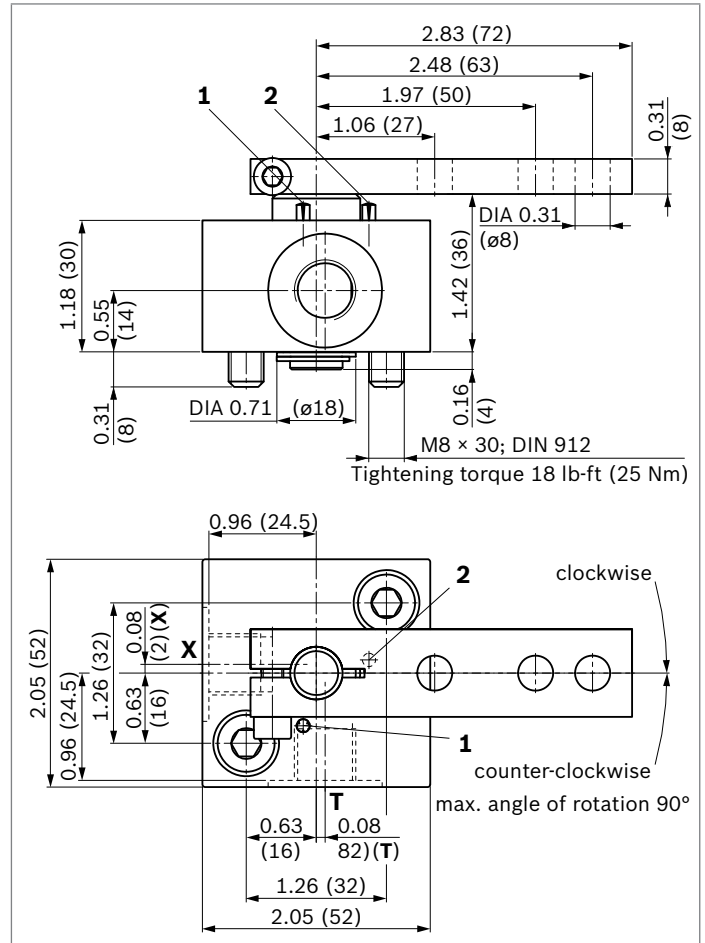

#### Notice

Limitation **1** and **2** are function stops for inching. They are not to be used as a mechanical limitation within the system. We recommend limiting the angle of rotation to 85° within the system.

Ports	Standard <sup>1)</sup>	Size	$p_{max}$ [psi (bar)] <sup>2)</sup>	State <sup>3)</sup>
<b>X</b>	ISO 11926	9/16 in -18 UNF-2B; 0.51 (13 deep)	580 (40)	O
<b>T</b>	ISO 11926	9/16 in -18 UNF-2; 0.51 (13 deep)	45 (3)	O

- 1) The countersink can be deeper than as specified in the standard.
- 2) Depending on the application, momentary pressure peaks can occur. Keep this in mind when selecting measuring devices and fittings.
- 3) O = Must be connected (plugged on delivery)

## Installation dimensions for coupling assembly

To ensure that rotating components (coupling hub) and fixed components (housing, snap ring) do not come into contact with each other, the installation conditions described here must be observed. This depends on the pump size and the splined shaft.

### SAE splined shaft (spline according to ANSI B92.1a)

Splined shaft **S** or **T**

The outer diameter of the coupling hub must be smaller than the inner diameter of the snap ring (dimension  $d_2$ ) in the area near the drive shaft collar (dimension  $x_2 - x_3$ ).

Observe diameter of relief on sizes 28 and 40.

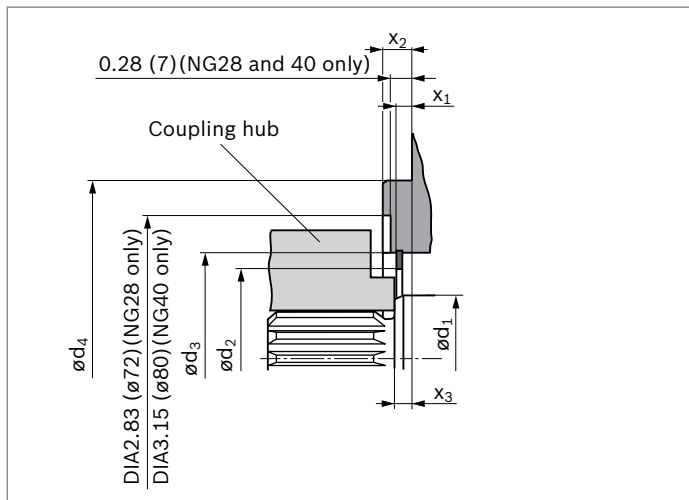

NG	$\odot d_1$	$\odot d_{2 \text{ min}}$	$\odot d_3$	$\odot d_4$	$x_1$	$x_2$	$x_3$	$x_4$
<b>28</b>	1.38	1.71	2.17±0.004	4.00	0.13 <sup>+0.008</sup>	0.37 <sub>-0.02</sub>	0.31 <sup>+0.035</sup> <sub>-0.024</sub>	0.39 <sup>+0.035</sup> <sub>-0.024</sub>
	(35)	(43.4)	(55±0.1)	(101.6)	(3.3 <sup>+0.2</sup> )	(9.5 <sub>-0.5</sub> )	(8 <sup>+0.9</sup> <sub>-0.6</sub> )	(10 <sup>+0.9</sup> <sub>-0.6</sub> )
<b>40</b>	1.57	2.02	2.48±0.004	5.00	0.17 <sup>+0.008</sup>	0.5 <sub>-0.02</sub>	0.31 <sup>+0.035</sup> <sub>-0.024</sub>	0.39 <sup>+0.035</sup> <sub>-0.024</sub>
	(40)	(51.4)	(63±0.1)	(127)	(4.3 <sup>+0.2</sup> )	(12.7 <sub>-0.5</sub> )	(8 <sup>+0.9</sup> <sub>-0.6</sub> )	(10 <sup>+0.9</sup> <sub>-0.6</sub> )
<b>56</b>	1.57	2.14	2.68±0.004	5.00	0.28 <sup>+0.008</sup>	0.5 <sub>-0.02</sub>	0.31 <sup>+0.035</sup> <sub>-0.024</sub>	0.39 <sup>+0.035</sup> <sub>-0.024</sub>
	(40)	(54.4)	(68±0.1)	(127)	(7.0 <sup>+0.2</sup> )	(12.7 <sub>-0.5</sub> )	(8 <sup>+0.9</sup> <sub>-0.6</sub> )	(10 <sup>+0.9</sup> <sub>-0.6</sub> )
<b>71</b>	1.77	2.62	3.19±0.004	5.00	0.28 <sup>+0.008</sup>	0.5 <sub>-0.02</sub>	0.31 <sup>+0.035</sup> <sub>-0.024</sub>	0.39 <sup>+0.035</sup> <sub>-0.024</sub>
	(45)	(66.5)	(81±0.1)	(127)	(7.0 <sup>+0.2</sup> )	(12.7 <sub>-0.5</sub> )	(8 <sup>+0.9</sup> <sub>-0.6</sub> )	(10 <sup>+0.9</sup> <sub>-0.6</sub> )
<b>90</b>	1.97	2.62	3.19±0.004	6.00	0.27 <sup>+0.008</sup>	0.5 <sub>-0.02</sub>	0.31 <sup>+0.035</sup> <sub>-0.024</sub>	0.39 <sup>+0.035</sup> <sub>-0.024</sub>
	(50)	(66.5)	(81±0.1)	(152.4)	(6.8 <sup>+0.2</sup> )	(12.7 <sub>-0.5</sub> )	(8 <sup>+0.9</sup> <sub>-0.6</sub> )	(10 <sup>+0.9</sup> <sub>-0.6</sub> )
<b>125</b>	2.17	3.00	3.58±0.004	6.00	0.28 <sup>+0.008</sup>	0.5 <sub>-0.02</sub>	0.31 <sup>+0.035</sup> <sub>-0.024</sub>	0.39 <sup>+0.035</sup> <sub>-0.024</sub>
	(55)	(76.3)	(91±0.1)	(152.4)	(7.0 <sup>+0.2</sup> )	(12.7 <sub>-0.5</sub> )	(8 <sup>+0.9</sup> <sub>-0.6</sub> )	(10 <sup>+0.9</sup> <sub>-0.6</sub> )



## Installation instructions

### General

The axial piston unit must be filled with hydraulic fluid and air bled during commissioning and operation. This must also be observed following a longer standstill as the axial piston unit may empty via the hydraulic lines.

Particularly in the installation position “drive shaft upwards”, filling and air bleeding must be carried out completely as there is, for example, a danger of dry running. The leakage in the housing area must be directed to the reservoir via the highest drain port (**T<sub>1</sub>**, **T<sub>2</sub>**). For combination pumps, the leakage must be drained off at each pump. If a shared drain line is used for several units, make sure that the respective case pressure is not exceeded. The shared drain line must be dimensioned to ensure that the maximum permissible case pressure of all connected units is not exceeded in any operating conditions, specifically on cold start. If this is not possible, separate drain lines must be laid if necessary.

To achieve favorable noise values, decouple all connecting lines using elastic elements and avoid above-reservoir installation.

Under all operating conditions, the suction line and drain line must flow into the reservoir below the minimum fluid level. The permissible suction height  $h_s$  results from the overall loss of pressure. However, it must not be higher than  $h_{s\ max} = 31.50\ in\ (800\ mm)$ .

The suction pressure at port **S** must also not fall below the minimum value of 12 psi (0.8 bar) absolute during operation (cold start 7.5 psi (0.5 bar) absolute).

### Installation position

See the following examples 1 to 12.

Further installation positions are available upon request.

Recommended installation position: 1 and 2.

### Notice

- ▶ Size 71 to 125  
For installation position “drive shaft upward”, an **R<sub>1</sub>** port is needed (special version).
- ▶ If filling the stroking chambers via **X<sub>1</sub>** to **X<sub>4</sub>** is not possible in the final installation position, then this must take place before installation, e. g. in installation position 2.
- ▶ To prevent unexpected actuation and damage, the stroking chambers must be air bled via the ports **X<sub>1</sub>**, **X<sub>2</sub>**, or **X<sub>3</sub>**, **X<sub>4</sub>** depending on the installation position.
- ▶ In certain installation positions, an influence on the control characteristic can be expected. Gravity, dead weight and case pressure can cause minor shifts in control characteristic curves and changes in response time.

### Below-reservoir installation (standard)

Below-reservoir installation means that the axial piston unit is installed outside of the reservoir and below the minimum fluid level of the reservoir.

Installation position	Air bleeding the housing	Air bleeding the stroking chamber	Filling
1	R	X <sub>1</sub> , X <sub>2</sub>	S + T <sub>1</sub> + X <sub>1</sub> + X <sub>2</sub>

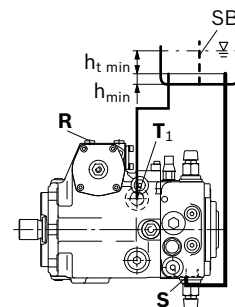

2	-	-	S + T <sub>2</sub>
---	---	---	--------------------

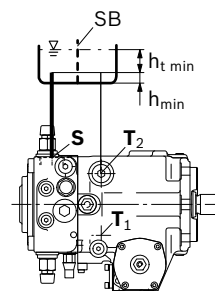

Installation position	Air bleeding the housing	Air bleeding the stroking chamber	Filling
3	-	X <sub>1</sub> , X <sub>2</sub>	S + T <sub>2</sub> + X <sub>1</sub> + X <sub>2</sub>

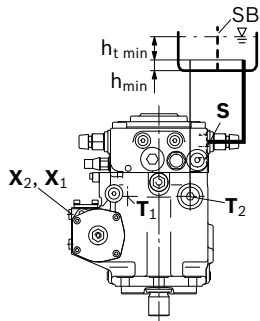

4	R <sub>1</sub>	X <sub>3</sub> , X <sub>4</sub>	S + T <sub>2</sub> + X <sub>3</sub> + X <sub>4</sub>
---	----------------	---------------------------------	------------------------------------------------------

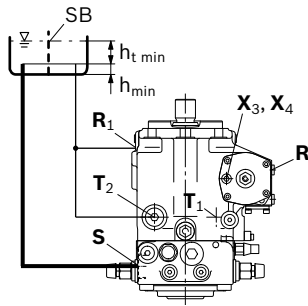

5	-	X <sub>3</sub>	S + T <sub>1</sub> + X <sub>3</sub>
---	---	----------------	-------------------------------------

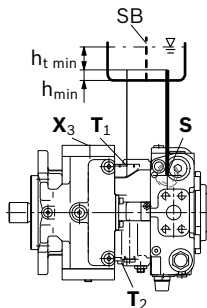

6	-	X <sub>4</sub>	S + T <sub>2</sub> + X <sub>4</sub>
---	---	----------------	-------------------------------------

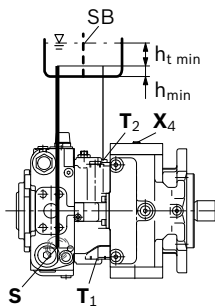

### Above-reservoir installation

Above-reservoir installation means that the axial piston unit is installed above the minimum fluid level of the reservoir.

Observe the maximum permissible suction height  $h_{S \max} = 31.50 \text{ in (800 mm)}$ .

Recommendation for installation position 10 (drive shaft upward): A check valve in the drain line (cracking pressure 7.5 psi (0.5 bar)) can prevent the housing area from draining.

Installation position	Air bleeding the housing	Air bleeding the stroking chamber	Filling
7	F <sub>2</sub> + R	X <sub>1</sub> , X <sub>2</sub>	F <sub>1</sub> + F <sub>2</sub> + X <sub>1</sub> + X <sub>2</sub>

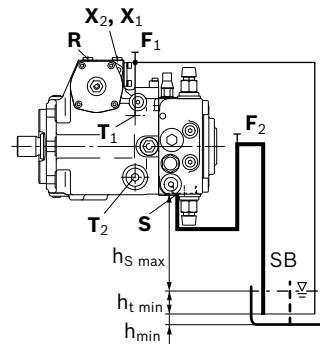

8	F <sub>2</sub> (S) + F <sub>1</sub> (T <sub>2</sub> )	-	F <sub>2</sub> (S) + F <sub>1</sub> (T <sub>2</sub> )
---	-------------------------------------------------------	---	-------------------------------------------------------

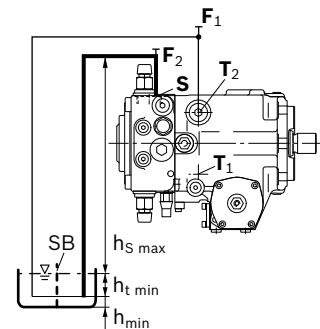

9	F <sub>2</sub> (S) + F <sub>1</sub> (T <sub>2</sub> )	X <sub>1</sub> , X <sub>2</sub>	F <sub>2</sub> (S) + F <sub>1</sub> (T <sub>2</sub> ) + X <sub>1</sub> + X <sub>2</sub>
---	-------------------------------------------------------	---------------------------------	-----------------------------------------------------------------------------------------

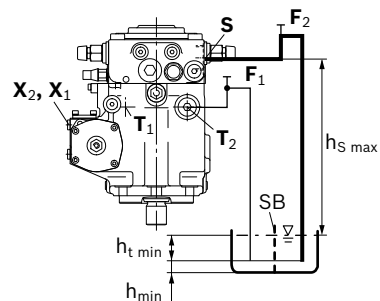

Installation position	Air bleeding the housing	Air bleeding the stroking chamber	Filling
<b>10</b>	$F_2 + R_1$	$X_3, X_4$	$F_1 + F_2 + X_3 + X_4$

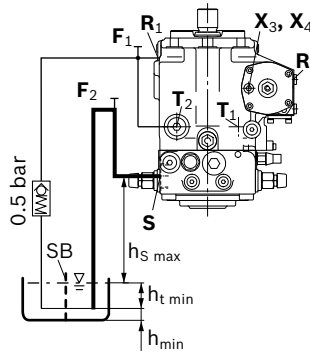

<b>11</b>	$F_2 (S) + F_1 (T_1)$	$X_3$	$F_2 (S) + F_1 (T_1) + X_3$
-----------	-----------------------	-------	-----------------------------

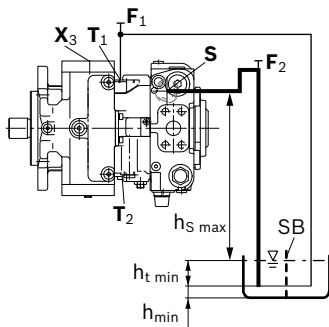

<b>12</b>	$F_2 (S) + F_1 (T_2)$	$X_4$	$F_2 (S) + F_1 (T_2) + X_4$
-----------	-----------------------	-------	-----------------------------

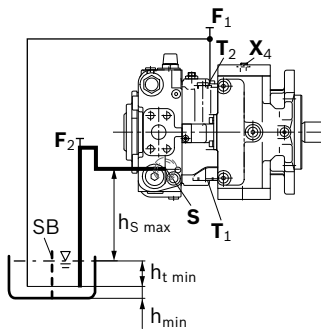

Key	
$F_1, F_2$	Filling / air bleeding
<b>R</b>	Air bleed port
$R_1$	Air bleed port (special version)
<b>S</b>	Suction port
$T_1, T_2$	Drain port
$X_1, X_2$	Control pressure port
$X_3, X_4$	Stroking chamber pressure port
<b>SB</b>	Baffle (baffle plate)
$h_{t \min}$	Minimum required immersion depth 7.87 in (200 mm)
$h_{\min}$	Minimum required distance to reservoir bottom 3.94 in (100 mm)
$h_{S \max}$	Maximum permissible suction height 31.5 in (800 mm)

#### Notice

Ports  $F_1$  and  $F_2$  are part of the external piping and must be provided on the customer side to make filling and air bleeding easier.

## Project planning notes

- ▶ The pump AA4VG is designed to be used in closed circuit.
- ▶ The project planning, installation and commissioning of the axial piston unit requires the involvement of qualified skilled personnel.
- ▶ Before using the axial piston unit, please read the corresponding instruction manual completely and thoroughly. If necessary, these can be requested from Bosch Rexroth.
- ▶ Before finalizing your design, please request a binding installation drawing.
- ▶ The specified data and notes contained herein must be observed.
- ▶ Depending on the operating conditions of the axial piston unit (working pressure, fluid temperature), the characteristic curve may shift.
- ▶ Preservation: Our axial piston units are supplied as standard with preservative protection for a maximum of 12 months. If longer preservative protection is required (maximum 24 months), please specify this in plain text when placing your order. The preservation periods apply under optimal storage conditions, details of which can be found in the data sheet 90312 or the instruction manual.
- ▶ Not all versions of the product are approved for use in a safety function according to ISO 13849. Please consult the responsible contact person at Bosch Rexroth if you require reliability parameters (e.g. MTTFD) for functional safety.
- ▶ Depending on the type of control used, electromagnetic effects can be produced when using solenoids. When a direct current is applied, solenoids do not cause electromagnetic interference nor is their operation impaired by electromagnetic interference.  
Other behavior can result when a modulated direct current (e.g. PWM signal) is applied. Potential electromagnetic interference for persons (e.g. persons with a pacemaker) and other components must be tested by the machine manufacturer.
- ▶ The pressure cut-off is not a safeguard against pressure overload. Be sure to add a pressure relief valve to the hydraulic system.
- ▶ Please note the details regarding the tightening torques of port threads and other threaded joints in the instruction manual.

- ▶ Working ports:
  - The ports and fastening threads are designed for the specified maximum pressure. The machine or system manufacturer must ensure that the connecting elements and lines correspond to the specified application conditions (pressure, flow, hydraulic fluid, temperature) with the necessary safety factors.
  - The working ports and function ports are only intended to accommodate hydraulic lines.

## Safety instructions

- ▶ During and shortly after operation, there is a risk of getting burnt on the axial piston unit and especially on the solenoids. Take appropriate safety measures (e.g. by wearing protective clothing).
- ▶ Moving parts in control equipment (e.g. valve spools) can, under certain circumstances get stuck in position as a result of contamination (e.g. impure hydraulic fluid, abrasion, or residual dirt from components). As a result, the hydraulic fluid flow and the build-up of torque in the axial piston unit can no longer respond correctly to the operator's specifications. Even the use of various filter elements (external or internal flow filtration) will not rule out a fault but merely reduce the risk. The machine/system manufacturer must test whether remedial measures are needed on the machine for the application concerned in order to set the consumer being driven to a safe position (e.g. safe stop) and if necessary to ensure it is properly implemented.
- ▶ Moving parts in high-pressure relief valves may in certain circumstances become stuck in an undefined position due to contamination (e.g. impure hydraulic fluid). This can result in restriction or loss of the load holding function in lifting winches. The machine/system manufacturer must check whether additional measures are required on the machine for the relevant application in order to keep the load in a safe position and ensure they are properly implemented.

**Bosch Rexroth Corporation**  
Mobile Applications  
8 Southchase Court  
Fountain Inn, SC 29644-9018, USA  
Telephone (864) 967-2777  
Facsimile (864) 967-8900  
www.boschrexroth-us.com

© Bosch Rexroth AG 2016. All rights reserved, also regarding any disposal, exploitation, reproduction, editing, distribution, as well as in the event of applications for industrial property rights. The data specified within only serves to describe the product. No statements concerning a certain condition or suitability for a certain application can be derived from our information. The information given does not release the user from the obligation of own judgment and verification. It must be remembered that our products are subject to a natural process of wear and aging.